



Telstar® BiOptima

Class I & Class II Biological Safety Cabinets

Advanced & ergonomic design

Comfortable and easy to use

Low energy consumption

Enhanced safety features

Low maintenance



Telstar BiOptima

Telstar **BiOptima** Series, our newest range of high quality Class I & Class II Biological Safety Cabinets ensures the highest level of protection for operator, product and environment, minimizing hazards inherent to working with agents assigned to biosafety levels 1, 2 and 3.

This series has been designed according to the highest standards of quality, biological safety, reliability, ergonomics and usability and meets the latest customer requirements such as low energy consumption and low sound level.

- *Low energy consumption*
- *Low sound level*
- *Superior quality*
- *High performance*
- *Ergonomic design*
- *Easy to operate*
- *Easy to clean*
- *Easy to decontaminate*
- *Low maintenance*
- *Easy installation*
- *According highest standards*
- *Microprocessor safety control*
- *GMP and PIC's compliant*
- *Enhanced safety features*



Certified Safety: EN 12469

The **BiOptima** 4 & 6 and **Cyto** 4 & **Cyto** 6 cabinets are independently tested and certified by TÜV Nord, the main certification body in Europe, to guarantee conformity to standard EN 12469 for Class II biological safety cabinets (30% exhaust, 70% recirculation unit). The **BiOptima** is specified for working with levels 1, 2 and 3 pathogenic agents. It also conforms to the main requirements NSF/ANSI 49 (Class II A2), JIS K3800, SFDA YY-0569 and AS2252.



BiOptima ONE, Biological Safety Cabinet Class I

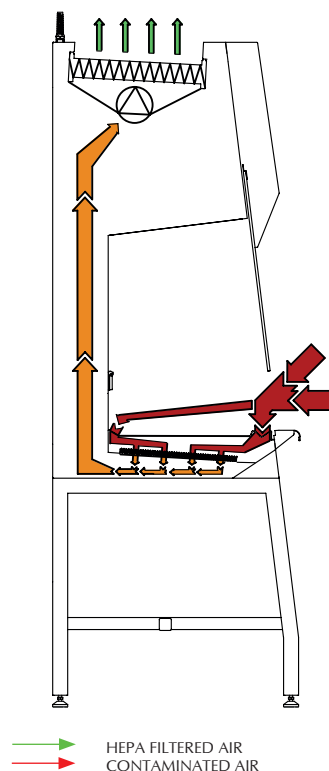

Telstar BiOptima ONE is a range of high quality Class I Biological Safety Cabinet, ensuring the highest level of protection for operator and environment.

Basic principle

The principle of BiOptima ONE is total extraction of the air through a HEPA filter. Ambient air is drawn from the front opening and extracted through the H14 HEPA filter, to ensure no harmful particles are released into the environment.

Applications

BiOptima One is designed for microbiological research with biological BSL 1 and 2 agents. Centrifuges, harvesting equipment and other equipment dedicated to procedures with the potential to generate aerosols can be easily placed inside the cabinet.

Available sizes

BiOptima One is standard available in 3,4 ft (90 and 120 cm approx.) width

TECHNICAL SPECIFICATIONS	units	BiOptima ONE 3	BiOptima ONE 4
External dimensions (WxDxH)	mm	1033x797x1450	1338x797x1450
Internal dimensions (WxDxH)	mm	885x548x666	1190x548x666
Shipping dimensions (WxDxH)	mm	1165x870x1770	1430x870x1770
Weight	Kg	180	210
Shipping weight	Kg	213	245
Front entry air speed	m/ser	0.9	0.9
Extraction flow rate	m ² /h	572	769
Power	W	150	190
Voltage (others available upon request)	V	230	230
Frecuency (other available upon request)	Hz	50/60	50/60
Lighting	LUX	≥ 850	≥ 1000
Sound Vibration	dBA	<55	<58
Filters	Prefilter	G3	G3
	HEPA Filter	H14	H14

BiOptima, Biological Safety Cabinet Class II

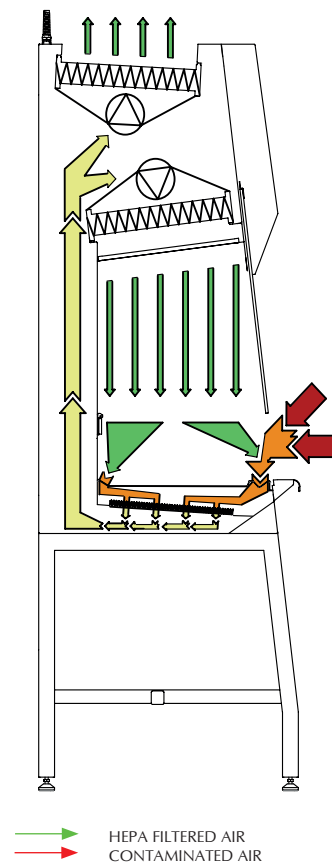
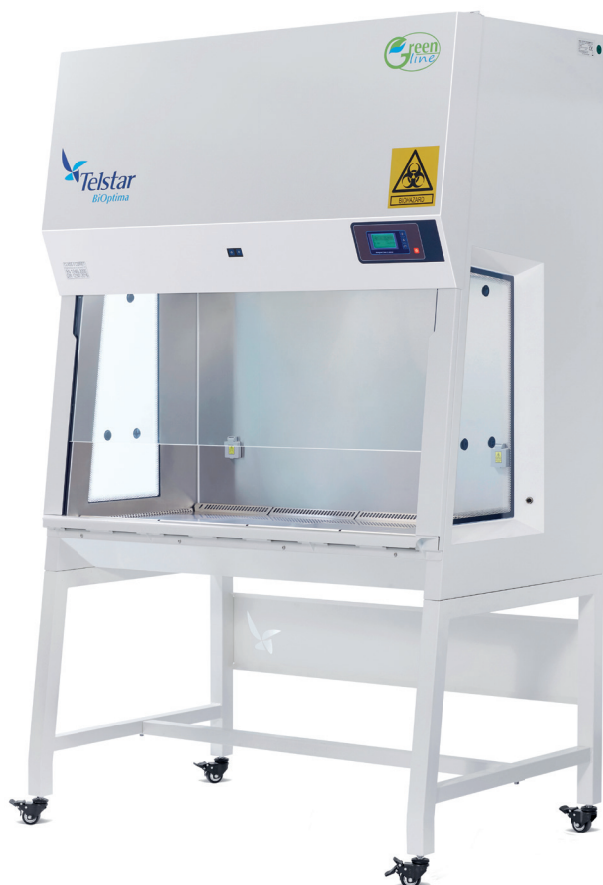

Basic principle

BiOptima provides operator protection by inflow, product protection by HEPA-filtered laminar downflow in the working area (30% exhaust; 70% recirculation) and environmental protection by HEPA-filtered exhaust air.

Applications

BiOptima is designed for microbiological research with biological agents (e.g. bacteria, viruses, etc) and allergens.

Available sizes

BiOptima is standard available in 3, 4, 5 and 6 ft (90, 120, 150 and 180 cm approx.) width.

TECHNICAL SPECIFICATIONS	units	BiOptima 3	BiOptima 4	BiOptima 5	BiOptima 6
External dimensions (WxDxH)	mm	1033x797x1450	1338x797x1450	1643x797x1450	1948x797x1450
Internal dimensions (WxDxH)	mm	885x548x666	1190x548x666	1495x548x666	1800x548x666
Shipping dimensions (WxDxH)	mm	1165x870x1770	1430x870x1770	1775x870x1770	2080x870x1770
Weight	Kg	190	220	250	285
Shipping weight	Kg	218	250	300	320
Laminar flow speed	m/s	0.35	0.35	0.35	0.35
Front entry air speed / extraction flow rate	m/s m ³ /h	0.6 (382)	0.65 (552)	0.6 (646)	0.6 (773)
Power	W	150	190	220	240
Voltage (others available upon request)	V	230	230	230	230
Frequency	Hz	50	50	50	50
Lighting	Lux	≥ 900	≥ 1000	≥ 1000	≥ 1000
Sound	dBA	≤ 53	≤ 58	≤ 58	≤ 58
Vibration	mm RMS	-	< 0.005	-	< 0.005
Filters	Pre Filter	G3	G3	G3	G3
	Downflow Hepa Filter	H14	H14	H14	H14
	Exhaust HEPA Filter	H14	H14	H14	H14
Air Quality	ISO 4 in accordance with ISO CD 14644-1: 353 part. ≥ 0.5 µm/m ³ ; 10000 part. ≥ 0.1 µm/m ³				

BiOptima CYTO, Biological Safety Cabinet Class II for Cytotoxics

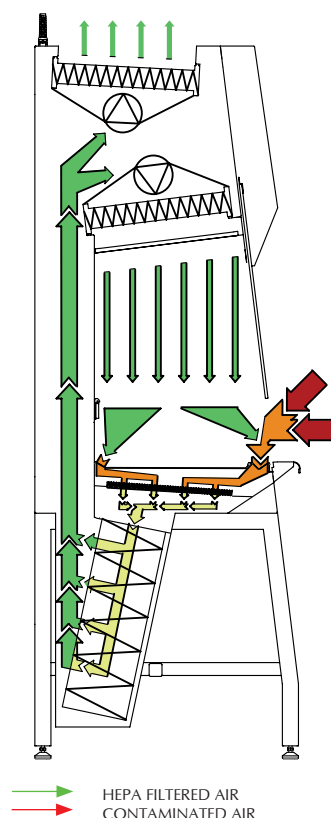

Basic principle

BiOptima Cyto is equipped with additional V-shaped HEPA filters underneath the work surface, which filter the inflow air and keep the internal construction of the cabinet free of contamination and therefore ensures the utmost safety for high risk applications. Safe replacement of the V-shaped HEPA filters is possible while the operator is protected by inflow air

Applications

BiOptima Cyto is designed for high risk microbiological and high toxic applications, such as the production of cytotoxic medicines, as specified by the DIN12980 Standard.

Available sizes

BiOptima Cyto is standard available in 4 and 6 ft (120 and 180 cm) width.

TECHNICAL SPECIFICATIONS	units	BiOptima Cyto 4	BiOptima Cyto 6
External dimensions (WxDxH)	mm	1338x797x2212	1948x797x2212
Internal dimensions (WxDxH)	mm	1190x548x666	1800x548x666
Shipping dimensions (WxDxH) (BOX1)	mm	1430x870x1770	2080x870x1770
Shipping dimensions (WxDxH) (BOX2)	mm	1430x870x1070	2080x870x1070
Weight	Kg	285	380
Shipping weight (BOX 1)	Kg	250	320
Shipping weight (BOX 2)	Kg	110	135
Laminar flow speed / laminar flow rate	m/s m ³ /h	0.35	0.35
Front entry air speed / extraction flow rate	m/s m ³ /h	0.60 (510)	0.65 (773)
Power	W	283	420
Voltage (others available upon request)	V	230	230
Frequency	Hz	50	50
Lighting	Lux	≥ 1000	≥ 1000
Sound	dBA	≤ 60	≤ 60
Vibration	mm RMS	< 0.005	< 0.005
Filters	Safe Change	H14	H14
	(V shape Hepa Filters)		
	Downflow Hepa Filter	H14	H14
	Exhaust HEPA Filter	H14	H14
Air Quality		ISO CD 14644-1: 353 part. ≥ 0.5 μm/m ³ ; 10000 part. ≥ 0.1 μm/m ³	

BiOptima EXA: Biological Safety Cabinet Class II type B2 Total Exhaust

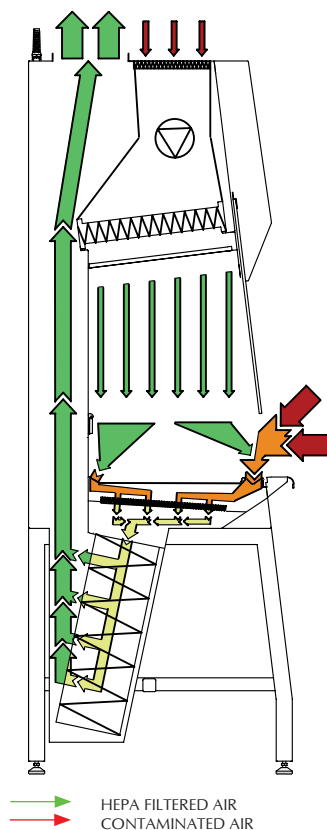

Basic principle

BiOptima EXA provides operator protection by inflow through the front grill, product protection by HEPA-filtered laminar downflow in the working area (100% exhaust) and environmental protection by HEPA-filtered exhaust air (not included with the cabinet).

Applications

BiOptima EXA is designed for hazardous airborne application like volatiles, mists or vapors beside high microbiological and high toxic application. Designed also according to NSF 49.

Available sizes

BiOptima EXA is standard available in 4, and 6 ft (120 and 180 cm approx.) width.

TECHNICAL SPECIFICATIONS	units	BiOptima EXA 4	BiOptima EXA 6
External dimensions (WxDxH)	mm	1338x797x2212	1948x797x2212
Internal dimensions (WxDxH)	mm	1190x548x666	1800x548x666
Shipping dimensions (WxDxH) (BOX1)	mm	1430x870x1770	2080x870x1770
Shipping dimensions (WxDxH) (BOX2)	mm	1430x870x1070	2080x870x1070
Weight	Kg	285	380
Shipping weight (BOX 1)	Kg	250	320
Shipping weight (BOX 2)	Kg	110	135
Laminar Flow speed	m/s	0.35	0.35
Front entry air speed / Extraction flow rate	m/s m ³ /h	0.6 (1303)	0.6 (1971)
Power	W	200	350
Voltage (others available upon request)	V	230	230
Frequency (others available upon request)	Hz	50/60	50/60
Lighting	Lux	≥ 1000	≥ 1000
Sound Vibration	dBA	< 52	< 55
Filters	Pre Filter	G3	G3
	Safe Change (V Shase Hepa Filters)	H14	H14
	Downflow	H14	H14
Air Quality	ISO 4 in accordance with ISO CD 14644-1: 353 part. ≥ 0.5 μm/m ³ ; 10000 part. ≥ 0.1 μm/m ³		

Features & Benefits

Ergonomic design

At Telstar we strongly believe that comfort is essential when using a BSC. With **BiOptima**, a user centered cabinet has been developed.

Standard features are designed to offer maximum comfort and make the cabinet extremely user friendly.

- External armrest. Ergonomic epoxy coated arm rest contributes to the comfortable working position of the operator.
- 7° sloped front window with predefined working, open and close position for operator comfort.
- Electrically driven laminated safety glass front window.
- Diffused and dimmable LED lighting for visual comfort.
- Spacious working Area.
- Glass sides for improved visibility.
- Intuitive user interface.
- Superior Laminarity for class II Cabinets
- Low Operation cost
- Ergonomic lighting is positioned outside the work area. This does not disturb the downflow, nor create inconvenient shades, nor create obstructions during cleaning.
- User-friendly LCD control panel, positioned at an angle, showing the operator all relevant functions and alarms at a glance.

Easy to clean

BiOptima cabinet characteristics make the cleaning of the working area extremely easy

- Hinged front glass that allows complete opening of front window for easy access to the work area. Additionally, it will facilitate placing large equipment into the work area.
- One-piece inner chamber – Standard equipped with Stainless Steel chamber with rounded corners, allowing easy cleaning.
- Segmented work surface.
- The drip tray underneath the worktop collects spilled liquids up to 4 litres, preventing these liquids from entering parts of the cabinet that are difficult to clean.

Easy to service & decontaminate

- Standard pre-filter for extended HEPA lifetime. G3 Pre-filter prevents dust, dirt and particles entering the HEPA filters, tremendously increasing HEPA efficiency in time.
- Innovative, unique and patented 4F System (Fast, Friendly and eFFicient) to replace the downflow filter in Class II cabinets: the filter is easily accessible from the front of the cabinet and replaceable using a unique fast tightening/untightening device, reducing the time required to replace the filter.
- All parts requiring maintenance are easily accessible from the front of the cabinet
- Easy to upgrade
- Ready for accessory installation

Advanced safety features

Characteristics of **BiOptima** exceed the EN 12469 standards.

- Replaceable CG screen for improved laminarity
- Dedicated exhaust fan and speed sensors
- High Efficiency EC fans (EBM-PAPST)
- TÜV Nord Certification for 4, 6 (According to EN-12469) and Cyto 4, 6 (According to DIN 12980)
- V-shaped inflow grill provides superior safety by preventing operator arms accidentally blocking the inflow
- Glass sides for process supervision and improved visibility
- Electronically controlled airflow
- Advanced connectivity

General Specifications

- EC fans
- Electrical automatic sliding front window
- Hinged full opening of frontal window
- 7° sloped front window for a better working position
- 304L stainless steel chamber with rounded angles and hardened security glass sides
- G3 pre-filter & drip tray underneath working surface
- LED lighting
- Security anti-reflective front window with UV protection, with no visual obstacles on the lower edge
- Microprocessor control with filter-loading-self-compensation
- Main screen showing the different speed (laminar or inflow)
- Control panel with international colour code to indicate cabinet status
- UV light and fans with programmable timer
- Four predefined languages (Spanish, English, French and German)
- Easy access for maintenance from the front panel

Options and accessories

A full range of options and accessories to customise BiOptima cabinets available to fulfill any requirement:

- Stand supports (available in various options)
- Gas & Vacuum taps
- IT Configuration
- Charcoal filter
- Additional sockets
- Weighing stone
- Ducting accessories
- VHP Kit
- IQ/OQ documentation
- Waste port
- Particle Counter
- Humidity and T^a sensor
- Electrically adjustable stand support.



Check for the nearest Telstar office at
<https://www.telstar.com/international/>

Headquarters

Av. Font i Sagué, 55 T +34 937 361 600
08227 Terrassa (Spain) F +34 937 861 380

www.telstar.com
sales.laboratory@telstar.com



ISO 9001: Certified Company

BR-BIOPTIMA-EN-0322

Telstar reserves the right to improvements and specifications changes without notice.