

# **OPERATION & MAINTENANCE MANUAL**

**Laboratory Vertical Steam Sterilizers**

**(with cooling option)**

**models**

**2540, 3850, 3870 ELV**

**and**

**2540, 3850, 3870 ELVC**



## TABLE OF CONTENTS

Paragraph	Page No.
<b>1 GENERAL</b> .....	<b>4</b>
<b>1.1 Incoming Inspection</b> .....	<b>4</b>
<b>1.2 Warranty</b> .....	<b>4</b>
<b>1.3 Ordering Information</b> .....	<b>4</b>
<b>2 TECHNICAL DATA</b> .....	<b>6</b>
<b>2.1 Introduction</b> .....	<b>6</b>
<b>2.2 Operating Conditions</b> .....	<b>7</b>
<b>2.3 Directives and Standards</b> .....	<b>7</b>
<b>2.4 Environment Emission Information</b> .....	<b>7</b>
<b>2.5 Specifications</b> .....	<b>8</b>
<b>2.6 Loading Capacities</b> .....	<b>9</b>
<b>2.7 Utility</b> .....	<b>9</b>
<b>2.8 Marking</b> .....	<b>10</b>
<b>2.9 Water Quality</b> .....	<b>15</b>
<b>2.10 Safety Features</b> .....	<b>16</b>
<b>3 STERILIZATION PROGRAMS</b> .....	<b>19</b>
<b>3.1 Program 1 – Unwrapped Instruments</b> .....	<b>20</b>
<b>3.2 Program 2 – Unwrapped Delicate Instruments</b> .....	<b>21</b>
<b>3.3 Program 3 – Liquid</b> .....	<b>22</b>
<b>3.4 Program 4 – Liquid + Cooling</b> .....	<b>23</b>
<b>4 KEYBOARD (Keys and Display)</b> .....	<b>24</b>
<b>4.1 Description and Functions of the Front Panel Keyboard</b> .....	<b>25</b>
<b>4.2 Displayed Error and Operational Messages</b> .....	<b>27</b>
<b>5 CHECKING AND CHANGING PARAMETERS AND OTHER DATA</b> .....	<b>29</b>
<b>5.1 Main Menu</b> .....	<b>29</b>
<b>5.2 Parameters</b> .....	<b>30</b>
<b>5.3 Setting the Clock</b> .....	<b>31</b>
<b>5.4 History</b> .....	<b>32</b>
<b>6 PRINTER</b> .....	<b>33</b>
<b>6.1 Printer Operation</b> .....	<b>33</b>
<b>6.2 Printer Output</b> .....	<b>34</b>
<i>This page has been re-written.....</i>	<i>Error! Bookmark not defined.</i>
<b>6.3 DPU 30 Printer Handling</b> .....	<b>35</b>
<b>7 PREPARATION BEFORE STERILIZATION</b> .....	<b>36</b>
<b>7.1 Instruments</b> .....	<b>36</b>
<b>7.2 Textiles</b> .....	<b>37</b>
<b>7.3 Empty containers”</b> .....	<b>37</b>
<b>7.4 Tubing</b> .....	<b>38</b>
<b>7.5 Liquids</b> .....	<b>38</b>
<b>7.6 Loading</b> .....	<b>38</b>

<b>8</b>	<b>OPERATION</b> .....	<b>39</b>
	8.1 <i>Turning on the Autoclave</i> .....	39
	8.2 <i>Verification Before Operating the Autoclave</i> .....	39
	8.3 <i>Loading</i> .....	39
	8.4 <i>Operations</i> .....	39
	8.5 <i>End of the Cycle</i> .....	40
	8.6 <i>Unloading</i> .....	40
	8.7 <i>Stopping the Process</i> .....	41
	8.8 <i>Safety</i> .....	41
<b>9</b>	<b>DOOR SAFETY SYSTEM</b> .....	<b>42</b>
	9.1 <i>Solenoid Locking Safety Device</i> .....	42
	9.2 <i>Emergency Release</i> .....	42
<b>10</b>	<b>SERVICE AND MAINTENANCE</b> .....	<b>43</b>
	10.1 <i>Preventive Maintenance</i> .....	43
	10.2 <i>Replacing the Air Filter (ELVC only)</i> .....	45
	10.3 <i>Replacing the Door Gasket</i> .....	46
	10.4 <i>Checking the Safety Valve</i> .....	47
	10.5 <i>Cleaning Water Outlet Strainer</i> .....	48
<b>11</b>	<b>TROUBLESHOOTING</b> .....	<b>49</b>
<b>12</b>	<b>SPARE PARTS LIST</b> .....	<b>51</b>
<b>13</b>	<b>ACCESSORIES</b> .....	<b>51</b>

## TABLE OF CONTENT

<b>Drawings</b>	<b>Page No.</b>
<i>Overall Dimensions Drawing for 2540 ELV/ELVC</i> .....	<i>13</i>
<i>Overall Dimensions Drawing for 3850 / 3870 ELV/ELVC</i> .....	<i>14</i>
<i>Top View - Details</i> .....	<i>17</i>
<i>Rear View - Details</i> .....	<i>18</i>
<i>Baskets and Containers</i> .....	<i>50</i>

## **1 GENERAL**

### **1.1 Incoming Inspection**

Upon receiving your Tuttnauer Autoclave carefully inspect the outside of the shipping carton for signs of damage. If any damage to the carton is found note the location with respect to the autoclave and check that area of the autoclave carefully once it is fully unpacked. Observe packing method and retain packing materials until the unit has been inspected. Mechanical inspection involves checking for signs of physical damage such as: scratched panel surfaces, broken knobs, etc.

**If any damage is found contact your dealer as soon as possible so that they can file a claim with the shipping carrier and also notify Tuttnauer.**

All Tuttnauer products are carefully inspected prior to shipment and all reasonable precautions are taken in preparing them for shipment to assure safe arrival at their destination.

**Note:** Lifting and carrying should always be done by two people.

### **1.2 Warranty**

To activate your warranty or for warranty information on this unit please contact your dealer or Heidolph Brinkmann at one of the #'s listed below:

Heidolph Brinkmann, LLC, 1241 Jarvis Avenue, Elk Grove Village, IL 60007, 856-786-1448, Toll Free: 866-650-9604, Fax: 856-949-1167

Brinkmann Instruments (Canada) Ltd. 4160 Sladeview Crescent #6, Mississauga, Ontario L5N 2L8, Ph: (905) 569-0664, Toll Free: (866) 260-6069, Fax: (905) 569-0665

**Tuttnauer USA Co., Ltd.**, 25 Power Drive Hauppauge, NY 11788, USA  
(800) 624 5836, (631) 737 4850, Fax: (631) 737 0720  
e-mail: info@tuttnauerUSA.com.

**Note:**

If you have any questions or there are any difficulties with this instrument and the solution is not covered in this manual, please contact your dealer or Heidolph Brinkmann.

**Do not attempt to service this instrument yourself.**

### **1.3 Ordering Information**

Several items must be specified when ordering the unit from your dealer.

- The chamber diameter and chamber depth required
- Please specify the supply voltage available (i.e. 115v/208v; 1Ph/3Ph)
- The temperature scale needed (Celsius or Fahrenheit).
- The pressure scale needed (kPa or psi)

### **1.3.1 Options**

- Printer - An optional, built in, thermal printer is available
- Rapid Cooling – these units are available with or without Rapid Cooling for liquid cycles.
  - o The cooling option requires an additional water and compressed air connection.
  - o While cooling water is circulated around the outside of the chamber compressed air is used inside the chamber to maintain the liquid at a high boiling point.

### **1.3.2 Accessories**

- Baskets – Different size baskets are available for these units (see pages 49 & 50).

The baskets are made of stainless steel wire and have a handle. The basket allows the operator to load a large quantity of materials into the chamber.

- Stainless steel containers - Different size containers are available for these units (see pages 49 & 50).

The containers are designed for sterilizing waste material. The containers have vent holes along the upper rim.

## **2 TECHNICAL DATA**

### **2.1 Introduction**

Models 2540, 3850, 3870, ELV/ELVC are vertical sterilizers designed especially for sterilization of instruments, liquids and other materials in laboratories, research institutes, food laboratories and pharmaceutical facilities.

A special feature of the ELVC sterilizer is the ability is to rapidly cool down a liquid load at the end of the sterilizing portion of the cycle.

The sterilizer provides four fully automatic programs eliminating any need for operator intervention during a cycle. A computerized control unit enables precise control and monitoring of physical parameters and clear documentation of the sterilization cycles.

A safety valve, mounted at the back top of the autoclave, is set to 40psig and protects the system from excessive pressure.

The autoclave is equipped with a pressure gauge (for reference only) that can be used in case there is any problem with the electricity supply during the sterilization cycle. The pressure gauge can verify if there is pressure in the chamber before an attempt is made to open the door.

According to the standard for laboratory autoclaves these units are equipped with two temperature sensors that control the cycle and prevent the opening of the door if the temperature is too high.

This manual is intended to give the user a general understanding of how the autoclave works and indicates best ways to operate and maintain it in order to obtain optimum results and a trouble free operation.

After reading this manual, operating the autoclave should be straight forward. However, since the autoclave is built using high technology sensitive components, no attempt should be made by the user or any other unauthorized person to repair or re-calibrate it.

Only technical personnel having proper qualifications, holding technical documentation and having adequate test instrumentation, are authorized to install or undertake repair or service.



## 2.2 *Operating Conditions*

- The autoclave is for “Indoor use” only.
- Only autoclavable materials shall be used.
- The ambient temperature shall be in the range of 50°F - 104°F (10°C - 40°C) and a relative humidity up to 85%.
- The operation altitude of this autoclave is restricted to 6600ft (2000m).The ambient pressure shall not be lower than 11.6psi (80kPa)
- The autoclave shall not be used in a manner not specified in this manual!



### **Caution**

**Waste water should be brought into the public net in accordance with the local rules or requirements i.e. only non-hazardous liquids shall be disposed in public sewage!**

## 2.3 *Directives and Standards*

Every autoclave meets the following Standards:

### 2.3.1 *Technical Standards*

1. The pressure vessel is an integral part of the equipment and complies with the ASME code, Section VIII div.1 for unfired pressure vessels
2. UL-61010–2-041 & UL-61010–1: Safety requirements for medical device.
3. UL – 1998 Software in Programmable Components

### 2.3.2 *Quality standards*

The manufacturing plant meets the following quality standards:

1. EN ISO 9001:2000– Quality System
2. ISO 13485-2003 – Quality systems – Medical devices.

## 2.4 *Environment Emission Information*

- A. Peak sound level generated by the sterilizer is less than 70 / dBA with a back sound level of 60 dBA.
- B. Total heat transmitted by the sterilizer is less than 300 W/h

## 2.5 Specifications

### 2.5.1 Dimensions

DIMENSIONS		MODEL					
		2540		3850		3870	
		mm	inch	mm	inch	mm	inch
Chamber diameter		254	10.0	380	15.0	380	15.0
Chamber depth		419	16.5	480	19.9	680	26.8
Chamber volume		23 lit.	6.1 gal.	65 lit.	17.2 gal.	85 lit.	22.5 gal.
Overall dimensions	Height	643	25.3	745	29.4	925	3.4
	Width	496	19.5	650	25.6	650	25.6
	Length	333	13.1	500	19.7	500	19.7

### 2.5.2 Technical Data

PROPERTY	MODEL		
	2540	3850	3870
Chamber material	St. St. 316 Ti (1.4571)	St. St. 316 Ti (1.4571)	St. St. 316 Ti (1.4571)
Door material	ST.ST. 304L	ST.ST. 304L	ST.ST. 304L
Air supply pressure (ELVC only) after pressure reducer - psi (Bar)	45-58 (3.1-4.0)	45-58 (3.1-4.0)	45-58 (3.1-4.0)
Feed water pressure (ELVC only) after pressure reducer - psi (Bar)	17.4-26.1 (1.2-1.8)	17.4-26.1 (1.2-1.8)	17.4-26.1 (1.2-1.8)
Mineral free water pressure after pressure reducer - psi (Bar)	17.4-26.1 (1.2-1.8)	17.4-26.1 (1.2-1.8)	17.4-26.1 (1.2-1.8)
Net weight lb (kg)	105 (48)	187 (85)	220 (100)
Shipping volume ft <sup>3</sup> (m <sup>3</sup> )	7.1 (0.21)	19.8 (0.56)	19.8 (0.56)
Shipping weight lb (kg)	125 (57)	222 (101)	255 (116)

### 2.5.3 Electrical Data:

PROPERTY	MODEL		
	2540	3850	3870
Ampere	10A	15A	15A
Voltage	1Ph, 208V/60Hz	3Ph, 208V/60Hz	3Ph, 208V/60Hz
Power (Watts)	2400 W	6000 W	6000 W
Protection against electrical shock	Class I (IEC 60601-1)		

## 2.6 Loading Capacities

Model	Maximum load	
	liquid	instrument
2540	10 liters	22 lb
3850/70	20 liters	44 lb

### 2.6.1 Erlenmeyer Flasks

SIZE	2540	3850	3870
250 ml	2 x 5	3 x 12	4 x 12
500 ml	2 x 4	2 x 7	3 x 7
1000 ml	1	2 x 4	2 x 4
2000 ml	1	3	2 x 3
3000 ml	1	2	2 x 2
5000 ml	1	1	1

### 2.6.2 Medium Flasks (Schott)

SIZE	2540	3850	3870
250 ml.	2 x 8	3 x 18	4 x 18
500 ml	2 x 5	2 x 11	3 x 11
1000 ml	4	2 x 8	2 x 8
2000 ml	1	4	2 x 4
5000 ml	1	2	2
10000 ml	—	1	1

## 2.7 Utility

Utility		Value	
Electrical data	2540	Power	1Ph, 208V/60Hz
		Recommended Circuit Breaker	20A
	3850/70	Power	3 Ph, 208V/60Hz
		Recommended Circuit Breaker	3x20A
Compressed Air (ELVC only)		1/2", 60-120psi (4.1-8.3 Bar), 60 l/min	
Tap water (ELVC only)		1/2", 30-45 psi (2.1-3.1 Bar)	
Mineral free water		1/2", 30-45 psi (2.1-3.1 Bar)	
Drain		Must be able to withstand a minimum temp. of 190°F (88°C) min.	





#### Attention:

The electrical net must be protected with a current leakage safety relay.  
The electrical network must comply with local rules or regulations.

## 2.8 Marking

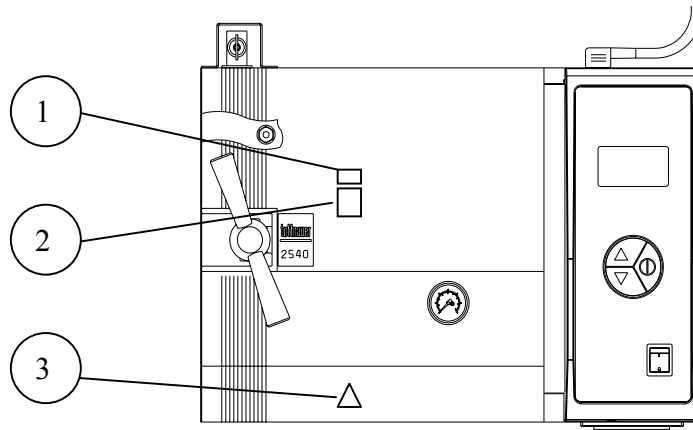
### MARKING ON TOP VIEW



No.	Marking	Explanation
1		This sticker provides a safety instruction for closing the door before beginning the cycle.
2	<p><b>CAUTION</b></p> <p>DOOR SHOULD BE OPENED ONLY WHEN:</p> <p>A. AUTOCLAVE SWITCH IS IN "ON" POSITION.</p> <p>B. LIQUID TEMPERATURE IS UNDER 80° C.</p> <p>C. INSTRUMENT TEMPERATURE IS UNDER 100° C.</p>	This sticker provides safety instructions for opening the door at the end of the cycle.
3		The meaning of this symbol is "Caution, hot surface!" It is to alert the user that the door may be very hot.

**MARKING ON SIDE VIEW**

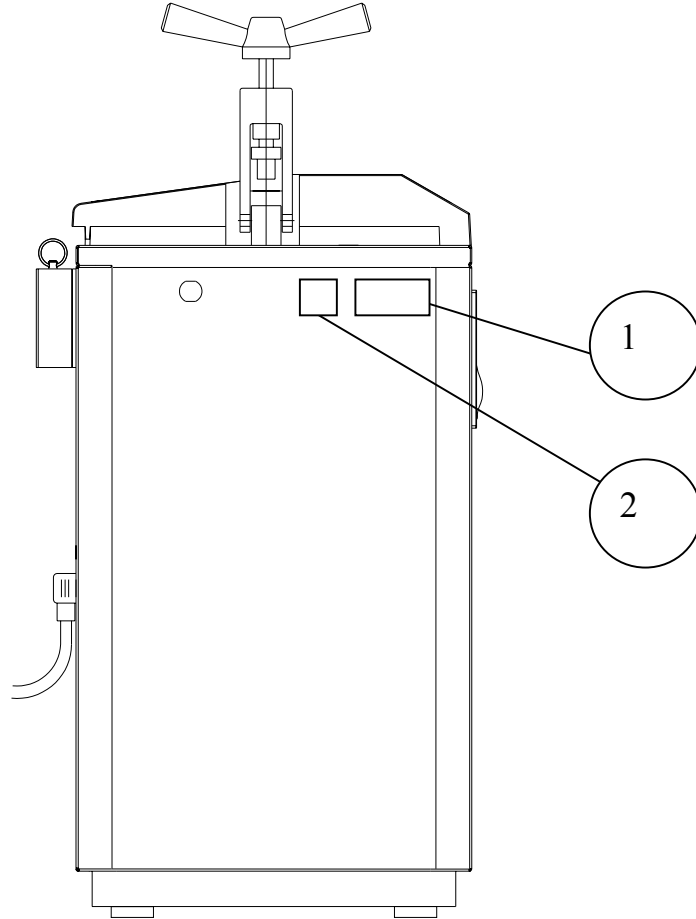

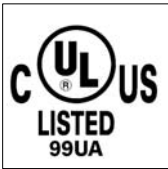
<i>No.</i>	<i>Marking</i>	<i>Explanation</i>
1	<p align="center">MADE IN ISRAEL BY TUTTNAUER CO.LTD BEIT SHEMESH, P.O.Box 170</p>	<p>This sticker provides the Manufacturer's name and address.</p>
2	 <p>The logo consists of a circle with 'UL' inside, and 'CSA' to its right. Below the circle, it says 'LISTED' and '99UA'.</p>	<p>This sticker indicates that the autoclave is UL and CSA approved.</p>

## MARKING ON REAR VIEW

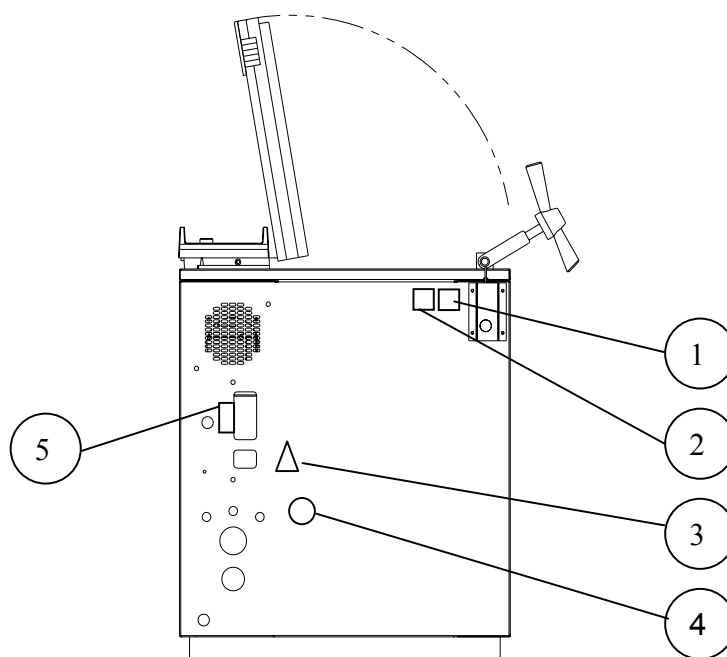

<i>No.</i>	<i>Marking</i>	<i>Explanation</i>
1		This sticker provides the following technical data: <ol style="list-style-type: none"> <li>1. Model name.</li> <li>2. Nature of electrical supply.</li> <li>3. Rated value of the supply voltage.</li> <li>4. Maximum rated input current.</li> <li>5. Autoclave's serial number.</li> </ol>
2		This sticker indicates that the pressure vessel of the autoclave is ASME approved.
3		The operator has to refer to the user manual.
4		This sticker indicated the place of the ground connection to the body of the autoclave.
5		This sticker shows the on-position and the off-position of the circuit breaker.

**OVERALL DIMENSIONS DRAWING FOR 2540 ELV/ELVC**

2540 ELVC

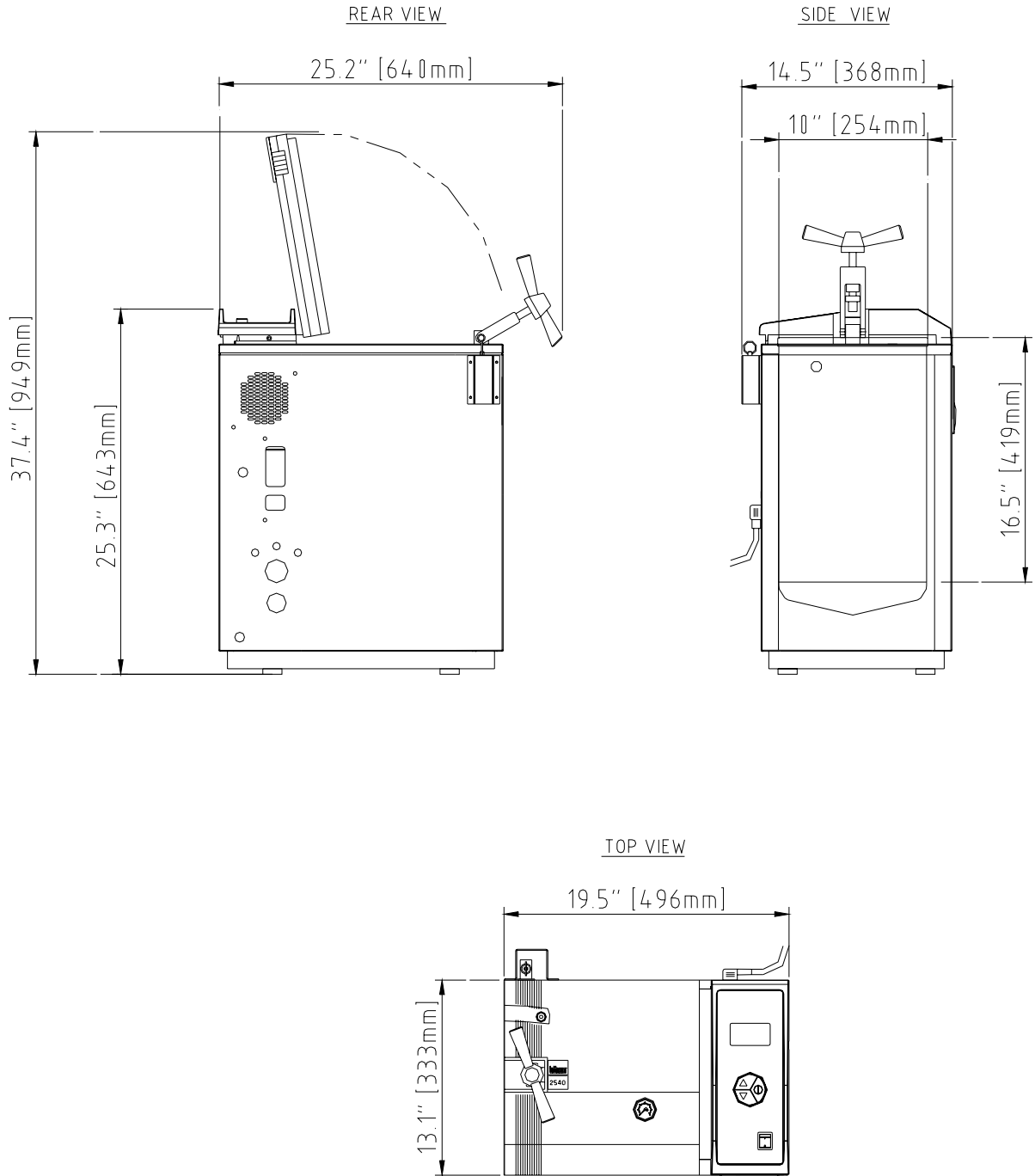

**OVERALL DIMENSIONS DRAWING FOR 3850 / 3870 ELV/ELVC**

3850 / 3870 ELVC

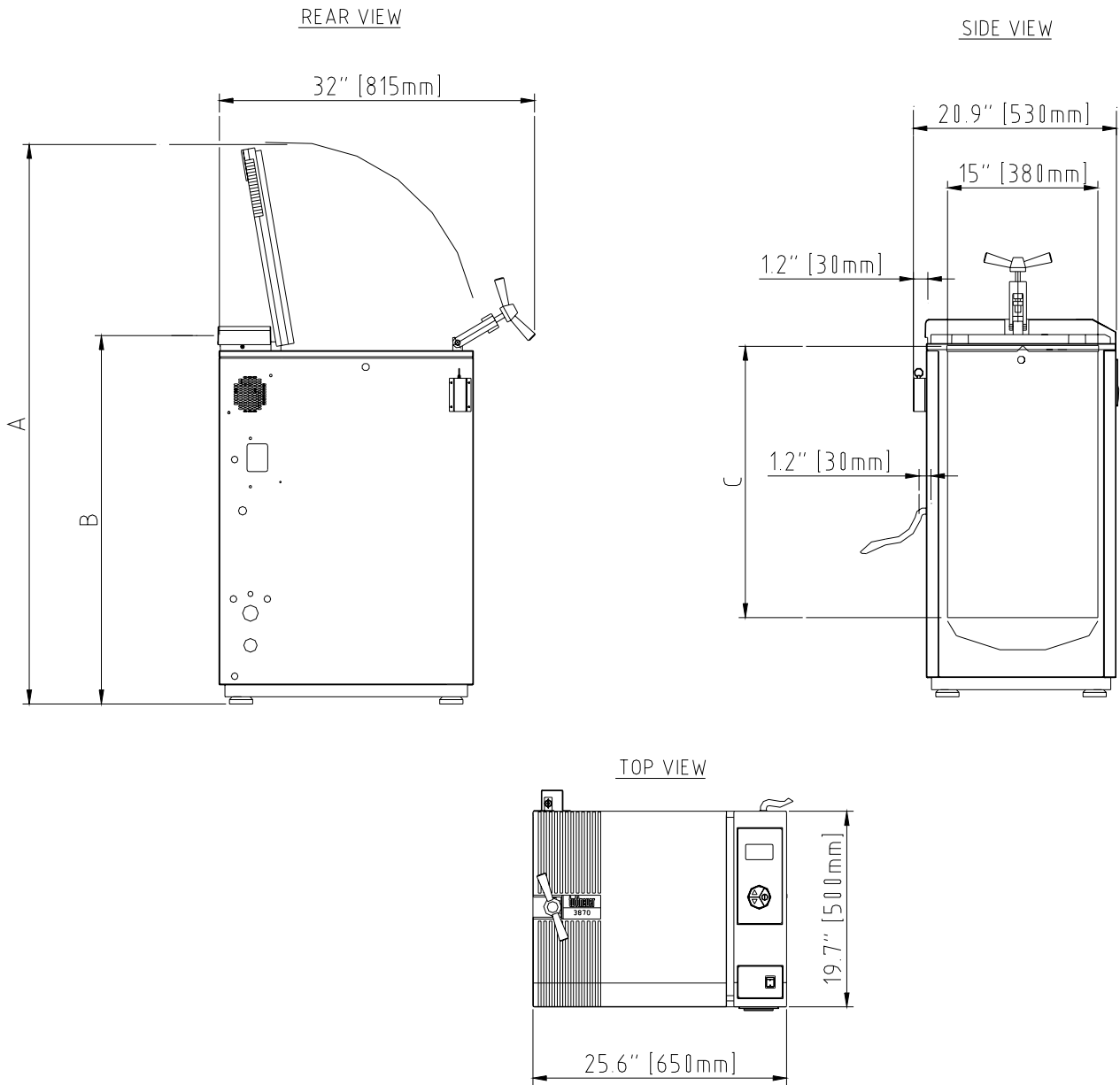

**Note:**

The dimensions A, B and C are different for the models 3850 and 3870, as indicated below

TYPE	A		B		C	
	mm	inch	mm	inch	mm	inch
<b>3850</b>	1220	48.0	745	29.4	480	19.9
<b>3870</b>	1400	55.1	925	36.4	680	26.8



## 2.9 Water Quality

### 2.9.1 Water for Steam Generation

The distilled or mineral – free water supplied to the autoclave should have the physical characteristics and maximum acceptable level of contaminants indicated in the table below:

**Physical Characteristics and Maximum acceptable  
contaminants levels in steam for sterilizers  
(According to EN 13060:2004).**

Element	Condensate – allowable content
Silicium oxide. SiO <sub>2</sub>	≤0.1 mg/kg
Iron	≤0.1 mg/kg
Cadmium	≤0.005 mg/kg
Lead	≤ 0.05 mg/kg
Rest of metals except iron, cadmium, lead	≤0.1 mg/kg
Chloride (Cl)	≤0.1 mg/kg
Phosphate (P <sub>2</sub> O <sub>5</sub> )	≤0.1 mg/kg
Conductivity (at 20°C)	≤3 µs/cm
pH value (degree of acidity)	5 to 7
Appearance	Colourless clean without sediment
Hardness (Σ Ions of alkaline earth)	≤0.02 mmol/l

The suitability of the water to be used should be verified by testing in accordance with the above table, at an authorized laboratory using acknowledged analytical methods.



**Attention:**

*We recommend testing the water quality once a month. The use of water for autoclaves that does not comply with the table above may have severe impact on the working life of the sterilizer and can invalidate the manufacturer's warranty.*

### **2.10 Safety Features**

This autoclave includes built-in safety features such as:

- Error message display to alert the operator of problems with the sterilization cycle.
- Electronic pressure and temperature measurement.
- Safety valve to prevent build-up of excessive pressure.
- Door switch to enable operation only when the door is closed.
- Water level safety device.
- Excess temperature protection.
- Electronic door interlock to permit door opening only when:
  1. The sterilized liquid temperature, (as measured by the two temperature sensors) is below the boiling point.
  2. The chamber pressure is the same as the ambient pressure.
  3. The electrical power is switched ON.

**TOP VIEW - DETAILS**

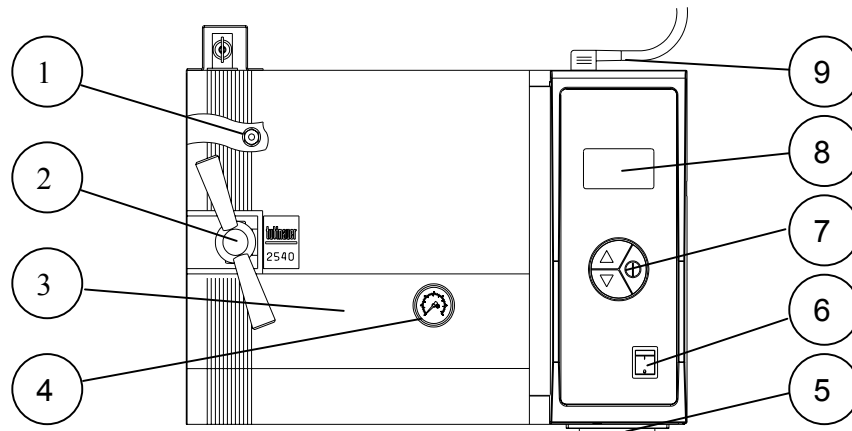

No.	Description
1	Door switch (behind the door)
2	Locking screw assembly
3	Door cover
4	Pressure gauge (2540 only)
5	Printer
6	On/Off switch
7	Keyboard
8	Display
9	Electrical cord

**REAR VIEW - DETAILS**

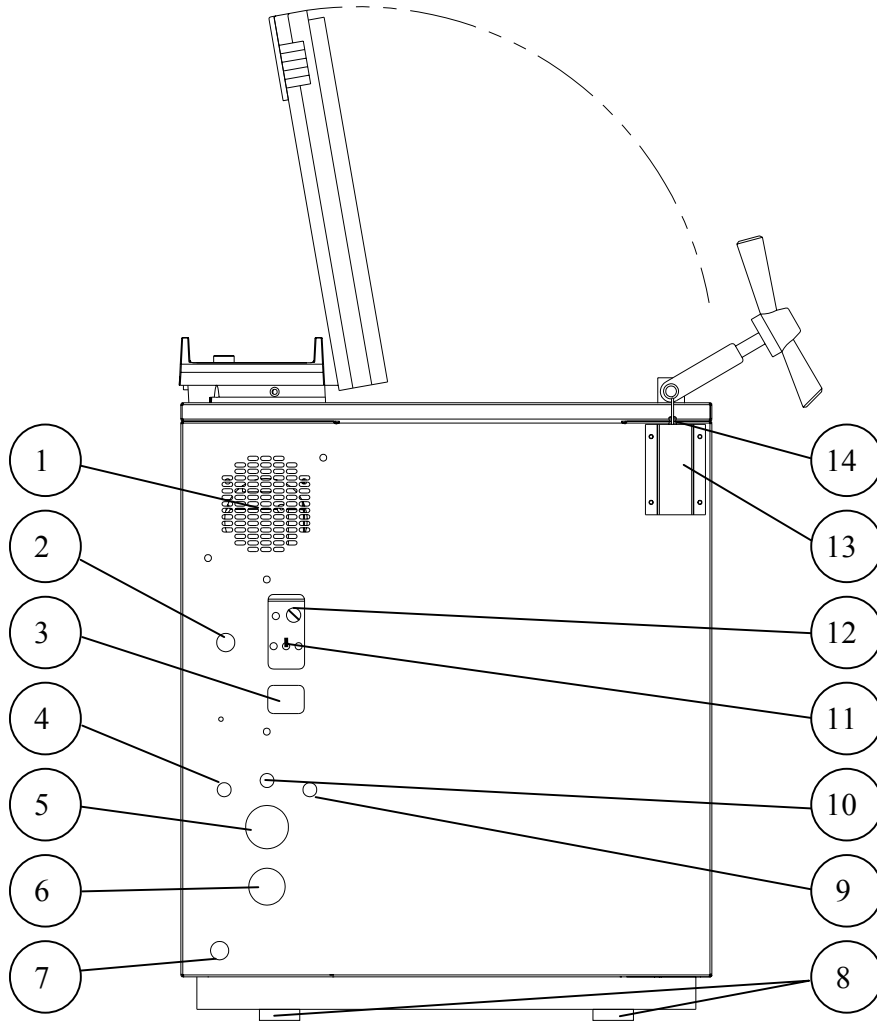

No.	Description
1	Control-unit ventilation grill
2	Thermal reset pushbutton
3	Electrical socket
4	Mineral free water inlet
5	Compressed air Pressure gauge (on ELVC only)
6	Compressed air Pressure regulator (on ELVC only)
7	Drain outlet
8	Autoclave's legs
9	Feed water inlet
10	Compressed air inlet (on ELVC models only)
11	Circuit breaker
12	Fuse, 0.5A
13	Safety relief valve shield
14	Safety relief valve ring (hidden)

### **3     *STERILIZATION PROGRAMS***

The autoclave offers 4 sterilization programs.

Changing any parameters needs to be done by a qualified technician.

<b>Sterilization Programs:</b>	<b>Fahrenheit</b>	<b>Celsius</b>
Program 1    Unwrapped instruments	273°F	134°C
Program 2    Unwrapped delicate instruments	250°F	121°C
Program 3    Liquid	250°F	121°C
Program 4    Liquid + Cooling	250°F	121°C

### 3.1 Program 1 – Unwrapped Instruments

Program 1 is recommended for sterilizing unwrapped instruments and materials where the materials manufacturer recommends autoclaving at a temperature of 273°F (134°C) for 4 minutes. The cycle ends with a rapid exhaust and no drying is available.



#### Nominal Parameters

- Sterilization temperature: 273°F (134°C)
- Sterilization time: 4 min.
- Dry time: None

#### Operations Sequence

- Water Inlet phase: Water enters the chamber, to the required level.
- Heating phase: Water heats up until steam reaches the preset sterilization temperature.
- Sterilization phase: Temperature is maintained constant at the preset value for the preset sterilization time.
- Exhaust phase: Condensate is rapidly exhausted from the chamber, until the pressure equalizes to atmospheric pressure.

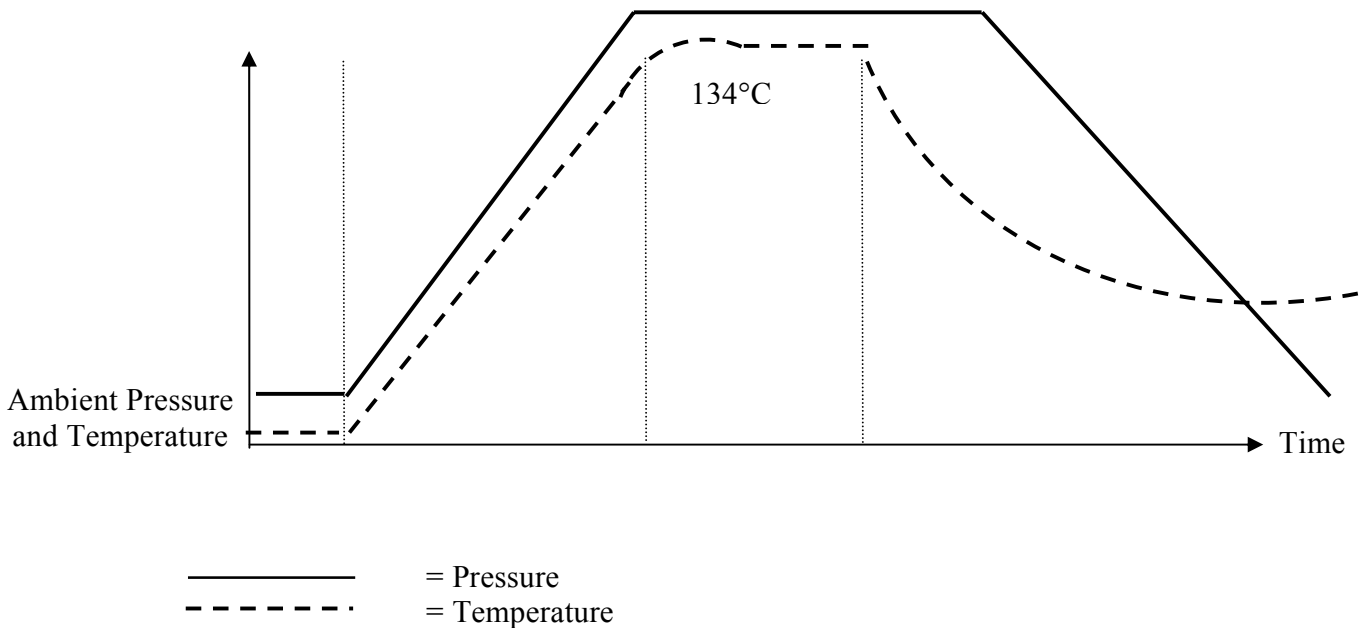

3.2 **Program 2 – Unwrapped Delicate Instruments**

Program 2 is recommended for sterilizing unwrapped instruments and materials where the materials manufacturer recommends autoclaving at a temperature of 250°F (121°C) for 20 minutes. The cycle ends with a rapid exhaust and no drying is available.



- Sterilization temperature: 250°F (121°C)
- Sterilization time: 20 min.
- Dry time: None

**Operations Sequence**

- Water Inlet phase: Water enters the chamber, to the required level.
- Heating phase: Water heats up until steam reaches the preset sterilization temperature.
- Sterilization phase: Temperature is maintained constant at the preset value for the preset sterilization time.
- Exhaust phase: Condensate is rapidly exhausted from the chamber, until the pressure equalizes to atmospheric pressure.

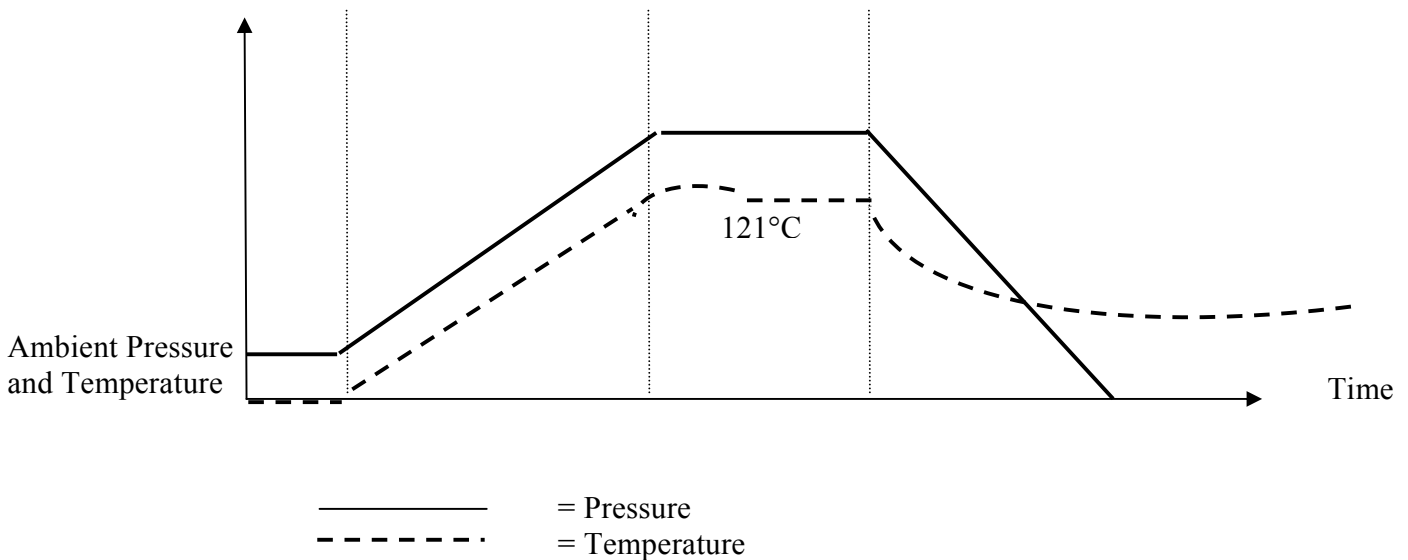

### 3.3 Program 3 – Liquid

Program 3 is intended to sterilize liquids. The sterilization temperature is 250°F (121°C) with no cooling. The cycle ends with slow exhaust to prevent bursting of the bottles.

Average cycle time: 2h15min for two containers holding 700ml each.



#### Nominal Parameters

- Sterilization temperature: 250°F (121°C)
- Sterilization time: 20 min.
- Dry time: None

#### Operations Sequence

- Water Inlet phase: Water enters the chamber, to the required level.
- Heating phase: Water heats up until steam reaches the preset sterilization temperature.
- Sterilization phase: Temperature is maintained constant at the preset value for the preset sterilization time.
- Exhaust phase: Condensate is slowly exhausted from the chamber, until the pressure equalizes to atmospheric pressure.

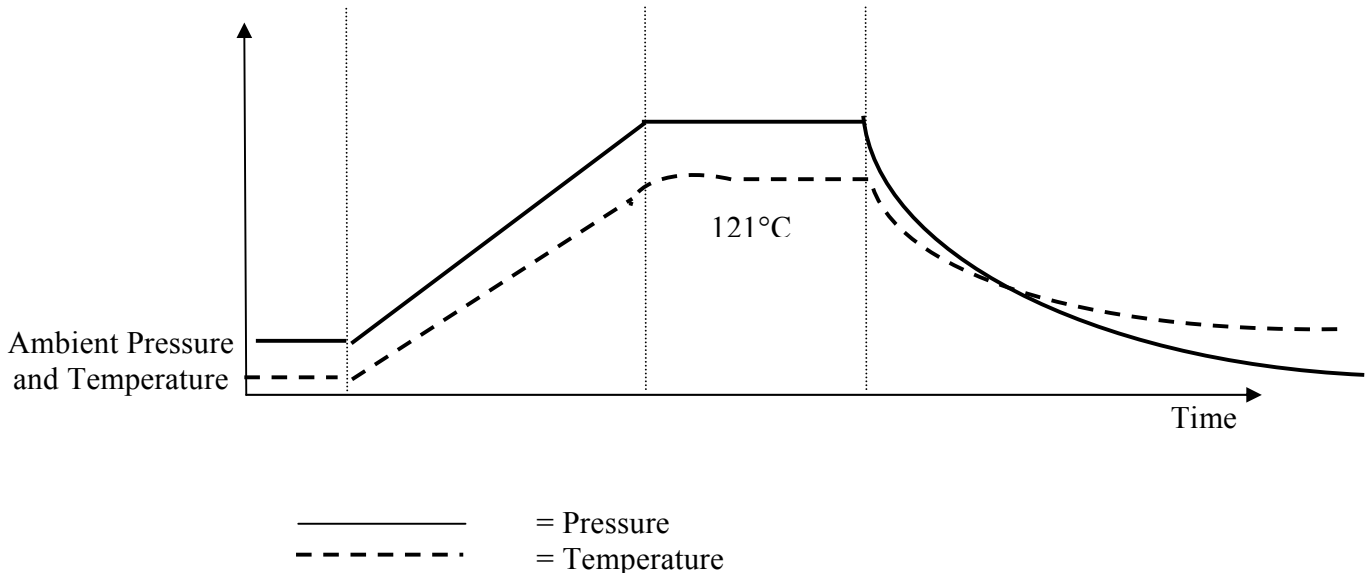



### 3.4 Program 4 – Liquid + Cooling

Program 4 is intended to sterilize liquids. The sterilization temperature is 250°F (121°C) with cooling. The cycle ends with cooling water circulated around the outside of the chamber while compressed air is used inside the chamber to maintain the liquid at a high boiling point.

- Average cycle time: 1h30min for two containers holding 700ml each.
- Average cooling stage time: 30min



#### Nominal Parameters

- Sterilization temperature: 250°F (121°C).
- Sterilization time: 20 min.
- Dry time: None

#### Operations Sequence

- Water Inlet phase: Water enters the chamber, to the required level.
- Heating phase: Water heats up until steam reaches the preset sterilization temperature.
- Sterilization phase: Temperature is maintained constant at the preset value for the preset sterilization time.
- Cooling phase: During the cooling phase tap water is circulated around the outside of the chamber to lower the temperature. Compressed air is used to maintain pressure in the chamber, which in turn maintains a high boiling point for the liquid just sterilized. This prevents bursting and spillover of the vessels containing the liquid as the temperature is reduced.. The temperature of the liquid needs to decrease to 90°C for the cycle to be completed. The forced cooling process shortens the cooling stage significantly.
- Fast exhaust phase: After reaching the end temperature 194°F (90°C), the exhaust valve is opened until the pressure in the chamber becomes equal to the atmospheric pressure.

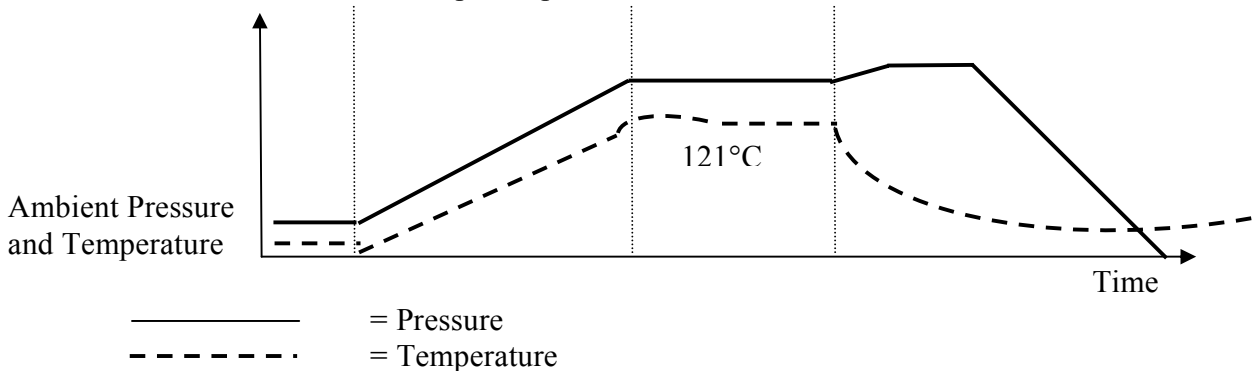

4 **KEYBOARD (Keys and Display)**

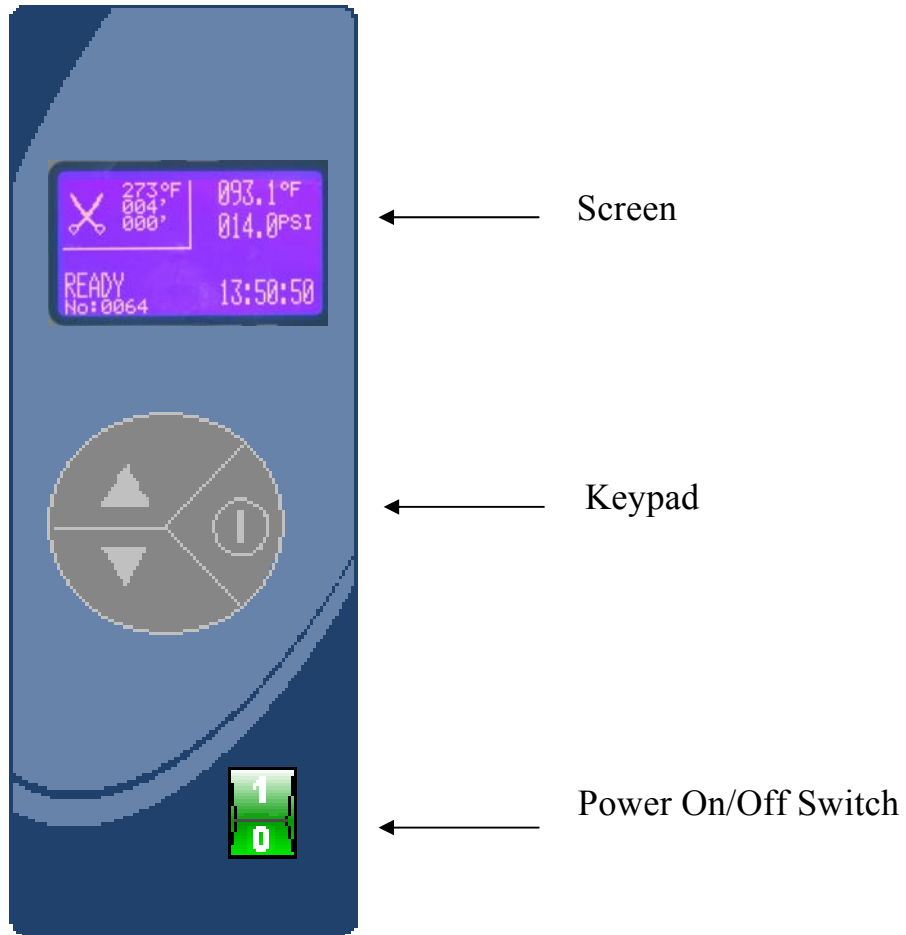

#### 4.1 *Description and Functions of the Front Panel Keyboard*

The front panel is composed of 2 sections:

1. Display screen.
2. Keypad.

##### 4.1.1 *Description of the main screen*

The graphic screen is used to display the current status of the autoclave along with Operational and Error Messages.

##### **Cycle information:**

- Cycle symbol
- Sterilization temperature
- Sterilization time
- Dry time

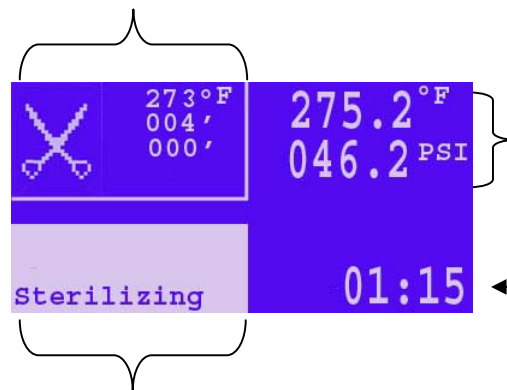

##### **Process information:**

- Operational messages
- Error messages
- Current stage

#### 4.1.2 *Description of the keypad*



The keypad which enables operation of the autoclave consists of 3 keys as described below.

##### **UP key**



##### **DOWN key**



The Up/Down keys are used to:

1. change program selection
2. program the clock
3. adjust sterilization time

##### **START/STOP key**

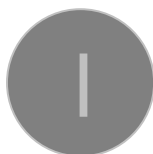

This key commands the following 3 functions:

- Starting the process.
- Stopping the process.
- Canceling the ERROR message from the command panel and opening the electric door locking.

#### 4.2 *Displayed Error and Operational Messages*

Message	Message Description	Corrective Action
Pt1 out	This message is displayed when the Chamber Temperature sensor Pt1 is disconnected or out of range.	Call for service.
Pt2 out	This message is displayed when the Chamber Temperature sensor Pt2 (additional safety feature) is disconnected or out of range.	Call for service.
Low Temperature	This message is displayed when the sterilization temperature wasn't reached.	<ul style="list-style-type: none"> <li>• Check that the autoclave is not overloaded (see sec. 2.6).</li> <li>• Check for steam leakage from the door.</li> <li>• If the problem persist, call the technician for service.</li> </ul>
High Temperature	This message is displayed if temperature rises 3°C above sterilization temperature during the sterilization stage for 10 seconds.	Call for service.
No Water	This message is displayed if during any cycles there is no water in the chamber.	<ul style="list-style-type: none"> <li>• Check the mineral free water supply is on.</li> <li>• If the problem persist, call for service.</li> </ul>
High Pressure	This message is displayed if the Chamber Pressure rises 20kPa above sterilization pressure for 5 seconds during the sterilization stage.	Call for service.
Low Pressure	This message is displayed if Chamber Pressure drops below the sterilization pressure for 5 seconds during the sterilization stage.	Call for service.
Manual Stop	This message is displayed if the STOP key is pressed and the cycle is aborted.	N/A
Low Heat	This message is displayed during the heating stage, if the system cannot reach the required chamber temperature within 20 minutes.	<ul style="list-style-type: none"> <li>• Check that the autoclave is not overloaded (see sec. 2.6).</li> <li>• Check for steam leakage from the door.</li> <li>• If the problem persists, call for service.</li> </ul>
Press Sensor Cutout	This message is displayed if pressure sensor 1 of the chamber is disconnected or if the pressure is out of range during Air-Removal and Heating stages.	Call the technician

Message	Message Description	Corrective Action
No Res Src.	This message is displayed if there is no water supply.	Check the connections to the water supply.
Temp2 High	This message is displayed, and door opening is prevented, if temperature sensor 2 senses a higher temperature than the pre-set end temperature.	Wait until the autoclave cools to "end-temp".
	Door is Open	Close the door to operate the autoclave. You can run a new cycle only when the door is close and the icon disappears.

## 5 **CHECKING AND CHANGING PARAMETERS AND OTHER DATA**

In order to set the autoclave's date and time, or change the sterilization time, or to print the 10 previous cycles, you need to access one of these sub-directories in the main menu.

1. Parameters
2. Set Clock
3. History

### 5.1 **Main Menu**

To enter the menu screen the machine must be on, but not running a cycle.

1. Press the UP and DOWN keys at the same time
2. Using the UP key enter code 0001
3. Press the START/STOP key to advance to the Set option.
4. Press the UP key to enter the code and access the menu.

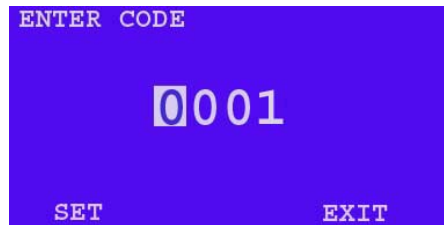

5. The following will be displayed:



## 5.2 Parameters

This directory enables you to see and modify sterilization time parameter (Dry time is not available on this unit).

1. Enter the MENU (see sec 5.1)
2. Using the UP/DOWN keys select the parameters option
3. Press the START/STOP key to enter that option
4. The CYCLE PARAMETERS screen is displayed

```
CYCLE PARAMETERS
Ster Time      030.0
Dry Time       000.0
Exit
```

You can see the parameters of the current cycle

1. Ster Time: sterilization time
2. Dry Time: the time of drying stage (N/A for this model)

You can increase or decrease the value of each parameter to reach the desired value.

NOTE: You can only change the values in the range from the default value up to 99.

1. To increase or decrease the sterilization time use the UP and DOWN keys.
2. To move the curse from one digit to another press the START/STOP key
3. After setting the sterilization time, use the START/STOP key, to go to "SAVE". Save the new time by pressing the UP key.
4. Use the START/STOP key to advance to "EXIT" and press the UP key to leave this section



### 5.3 *Setting the Clock*

This directory enables you to set the time and date.

1. Enter the MENU (see sec 5.1)
2. Using the UP/DOWN keys select the set clock option
3. Press the START/STOP key to enter that option
4. The SET CLOCK screen is displayed



Upon entering the set clock display, the time and date are shown. The cursor is blinking on the digits for the hour.

The time is displayed in a 24 hour format in the upper row in the form “hh:mm:ss”.

The date is displayed in the lower row in the form “MM:DD:YY”.

1. To increase or decrease the time or the date use the UP and DOWN keys.
2. To move the cursor from one digit to another press the START/STOP key.
3. After setting the time and date, use the START/STOP key, to go to “SAVE”. Save the new time and date by pressing UP key.
4. Use the START/STOP key to advance to “EXIT” and press the UP key to leave this section

## 5.4 *History*

This directory enables you to print the 10 previous cycles.

1. Enter the MENU (see sec 5.1)
2. Using the UP/DOWN keys select the history option
3. Press the START/STOP key to enter that option
4. The HISTORY screen is displayed

```
HISTORY
Log Load Nu: 0011
Log Load Nu: 0012
Log Load Nu: 0013
Empty
Empty
Exit
```

5. Choose the cycle that you want according to its number using the UP and DOWN keys.
6. Select it by pressing the START/STOP key.
7. The cycle is printed.
8. In order to leave this screen, go to the EXIT option using the UP and DOWN keys and select it by pressing the START/STOP key.

## **6 PRINTER**

### **6.1 Printer Operation**

The autoclave is equipped with a character printer, which prints a detailed history of each cycle performed by the instrument (for the record or for subsequent consideration).

The printing is made on thermal paper with 24 characters per line and contains the following information:

- Date started
- Time started
- Serial number of unit
- Software version
- Parameter version
- Load number
- Selected program
- Programmed Sterilization temperature
- Programmed Sterilization time
- Dry time ( N/A on this unit)
- Programmed End temperature
- Summary of performed cycle
- Date finished
- Time finished
- Operator initials

When the sterilization cycle begins the printer starts printing the above data.

After the preliminary cycle information is printed, the autoclave starts the cycle operation. The measured values from the two temperature probes and the pressure sensor are printed at fixed time intervals, according to the phase of the process, as shown in the sample print out (see sec 6.2).

The data is printed from the bottom up, beginning with the date and ending with “CYCLE ENDED!” for a complete cycle or “CYCLE FAIL!” for an aborted cycle.

For an example of a typical printout, see next page.

## 6.2 Printer Output

### PRINTER OUTPUT

### DESCRIPTION

Operator:

To be filled in manually by operator

Time: 09:17:34

Time sterilization cycle ended

Date: 10/03/2006

Date sterilization cycle ended.

### CYCLE ENDED!

085.7	082.9	017.4	Status of the autoclave during exhaust stage Temp. and pressure reading time in HH.MM.SS
E 00:40:03			
122.6	122.6	016.5	Status of the autoclave during cooling stage Temp. and pressure reading time in HH.MM.SS
C 00:34:51			
122.6	122.6	016.5	Status of the autoclave during sterilization stage Temp. and pressure reading time in HH.MM.SS
S 00:35:08			
*			Prints sterilization data every 60 seconds
*			
*			
121.2	121.1	016.2	Status of the autoclave during sterilization stage Temp. and pressure reading time in HH.MM.SS
S 00:14:51			
108.9	108.9	006.5	Status of the autoclave during heating stage Temp. and pressure reading time in HH.MM.SS
H 00:12:29			
*			Prints heating data every 3 minutes
*			
*			
023.2	023.0	000.2	Status of the autoclave during heating stage Temp. and pressure reading time in HH.MM.SS
H 00:00:29			
022.7	022.3	000.5	Status of the autoclave during water inlet stage Temp. and pressure reading time in HH.MM.SS
W 00:00:00			
C	C	psi	Temperature sensor 1 (°C)    Temperature sensor 2 (°C)    Chamber press. (psi)
End Temp	090.0min		End temperature for selected program.
Dry Time:	000.0min		Drying time for selected program (N/A on this unit).
Ster Time:	020.0min		Sterilization time for selected program.
Ster Temp:	121.1°C		Sterilization temperature in chamber for selected program
Cycle:	Liquid & C		Cycle name
Load number:	0017		Cycle counter
Param. Ver:	0031		Version of parameters setting.
Ver:	Lab 1.43		Software version.
Ser.Num:	02803304		Autoclave's serial number.
Time:	09:54:56		Time sterilization cycle started.
Date:	18/03/2009		Date sterilization cycle started.
POWER ON			The device is turned on

### Legend

<b>W</b> Water inlet	<b>C</b> Cooling stage
<b>H</b> Heating stage	<b>E</b> Exhaust stage
<b>S</b> Sterilization stage	<b>D</b> Dry stage

### 6.3 *DPU 30 Printer Handling*

#### 6.3.1 *Setting Paper*

1. Press the paper cover open button (#1) and open the paper cover (#3). Handle the paper cutter carefully not to cut your hand.
2. Set a paper roll as shown in the figure.
3. Close the paper cover (#3) by pressing both ends of the cover with the tip end of the paper extending out from the cutter.

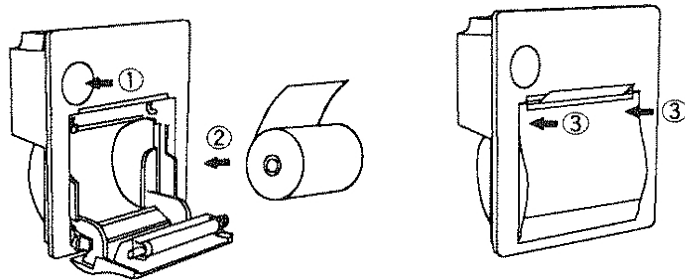

#### 6.3.2 *Maintenance*

1. Wipe off any soiling on the Printer's external surface with a soft cloth and a weak neutral detergent. After that, wipe the printer with a dry cloth.
2. **Caution:** Never disassemble the printer. Failure to follow this instruction may cause electric shock, overheating or burning of the printer adapter. Or an which may lead to fire.
3. The Printer is sensitive to moisture. Avoid splashing or spilling liquids on the Printer. Doing so can lead to electric shock or create a fire hazard.
4. Never touch the thermal head immediately after printing because it becomes very hot. Make sure that the thermal head is cool before setting paper or cleaning the thermal head.
5. Power OFF the autoclave in any of the following cases:
  - The printer does not recover from an error.
  - Smoke, strange noise or smells erupt from the printer.
  - A piece of metal or any liquid touches the internal parts or slot of the printer.
6. Notes on treatment of thermal papers:
  - Store the papers in a dry, cool and dark place.
  - Do not rub the papers with hard substance.
  - Keep the papers away from organic solvent.

## 7 **PREPARATION BEFORE STERILIZATION**

The purpose of packaging and wrapping of items for sterilization is to provide a protective barrier against recontamination after items are removed from the sterilizer. Packaging and wrapping materials should permit the removal of air from the pack, penetration of the sterilizing water vapor into the pack and removal of the sterilizing vapor.

The basic principle determining the size, mass and contents of instrument and hollowware packs is that the contents are sterile and dry immediately on completion of the drying cycle and removal of the pack from the sterilizer chamber.

Instruments to be sterilized must be free from all residual matter, such as blood, or organic tissue. Instruments must also be dry and free from mineral deposits. Such substances may cause damage to the instruments themselves or the sterilizer.

If the unit is equipped with a printer, check if a new roll of paper is needed.

### 7.1 **Instruments**

1. For all loads not containing liquids, insert the two temperature sensors (1) into the sensors holder (2) attached to the autoclave's door (3) (see picture below).

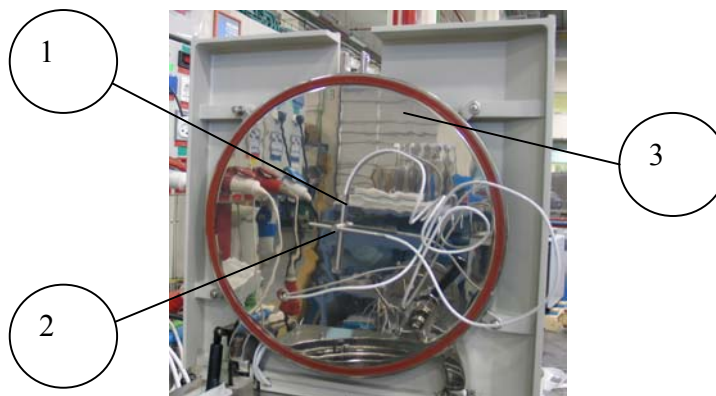

2. Clean instruments immediately after use to remove any residue. It is recommended that all instruments be ultrasonically cleaned using Tuttnauer's CLEAN AND SIMPLE enzymatic cleaning tablets or other suitable solution.
3. After cleaning, rinse instrument under tap water for 30 second and pat or air dry to remove residual minerals. If your tap water has a high mineral content rinse a second time in a bath of distilled water to remove minerals.
4. Follow the instrument manufacture's instructions on the use of products for cleaning and lubricating instruments that have been ultrasonically cleaned.
5. Be sure that instruments of dissimilar metals (stainless steel, carbon steel, etc.) are separated. Carbon steel instruments should be bagged or placed on autoclavable towels and not be allowed to come in contact with the stainless steel baskets (mixing will result in the oxidation of these metals).
6. Do not place materials to be sterilized against the chamber's wall. Place the material only in the basket.
7. When using a paper / plastic bag, the plastic side should always be down.

8. Check the instructions of the item manufacturer as to the proper procedure for sterilizing each item.
9. Items must be sterilized in an open position. Surfaces that are hidden because the item is in a closed position will not be exposed to the steam and will not be sterilized.
10. Use single-use wraps once only and discard after use.
11. Materials used for wrapping and packing, including materials used for inner wraps, shall be compatible with the item being packed and the sterilizing method selected.
12. Wrapped instrument should be placed in material which will allow steam penetration and promote drying, such as autoclave bags, autoclave paper, or muslin towels.
13. If necessary, disassemble or loosen multi-part instrument prior to packaging to permit the sterilizing agent to come into contact with all parts of the instrument.
14. Tilt items on edge that are prone to entrap air and moisture, e.g. hollowware, so that only minimal resistance to air removal, passage of steam and condensate will be met.
15. Load the basket loosely to capacity
16. Place a sterilization indicator strip in each basket.
17. Once a week, use a biological spore test indicator in any load to make sure sterilization is performed.
18. Make sure that all instruments remain apart during the sterilization cycle.

## **7.2 *Textiles***

1. For all loads not containing liquids, insert the two temperature sensors (1) into the sensor holder (2) attached to the autoclave's door (3) (see picture 7.1 #1).
2. Launder textile wraps prior to sterilization, but DO NOT use bleach.
3. Tilt textile packs on edge to provide minimal resistance to the removal of entrapped air.
4. Wrapped textiles should be placed in material which will allow steam penetration and promote drying, such as autoclave bags, autoclave paper, or muslin towels.
5. Materials used for wrapping and packing, including materials used for inner wraps, shall be compatible with the item being packed and the sterilizing method selected.
6. Load the basket loosely to capacity.
7. Place a sterilization indicator strip in each basket.

## **7.3 *Empty containers***

1. For all loads not containing liquids, insert the two temperature sensors (1) into the sensor holder (2) attached to the autoclave's door (3) (see picture 7.1 #1).
2. Place empty containers upside down to prevent accumulation of water.

#### 7.4 **Tubing**

Clean tubing and rinse with pyrogen - free water. Ensure both ends of the tube are open, and free of any sharp bends, twists or kinks.

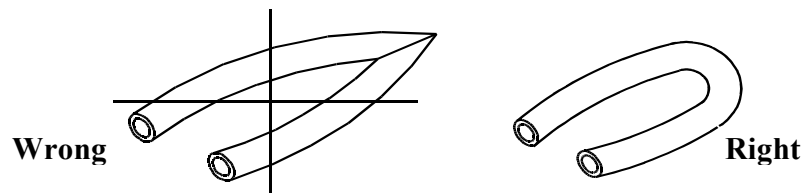

#### 7.5 **Liquids**

1. Use only heat-proof glass containers, filled to 2/3 capacity.
2. Place the two temperature sensors located on the door, into two separate liquid containers. These are used to control the program temperature and ensure the the safety of the operating cycle.

#### 7.6 **Loading**

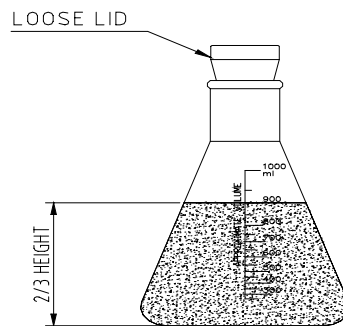

The loading of goods and instruments is done by means of two stacked baskets. The baskets are provided with handles for the convenience of the operator.

There are 2 types of baskets:

1. Baskets that are fully perforated.
2. Baskets that are not perforated except one row of holes adjacent to the basket's top. These baskets are intended for waste cycles, to avoid clogging of the vessel's drainage pipe by overflowing liquids.

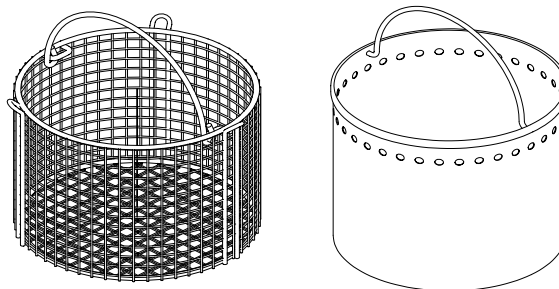



## 8 OPERATION

### 8.1 Turning on the Autoclave

To start the system, turn on the main power switch located at the bottom right corner of the keyboard panel (see sec 4).

The software name and version number are displayed briefly then the main screen is displayed as shown:



### 8.2 Verification Before Operating the Autoclave

- Verify that the mineral free water supply is connected to the mineral free water inlet.

**NOTE: the electrical conductivity of the water must not exceed 15 micro-siemens.**

- Verify that the date and the time are correct (see: SETTING THE CLOCK sec 5.2)

### 8.3 Loading

Correct loading of the autoclave is essential to successful sterilizing for several reasons. Efficient air removal from the chamber and the load will permit effective steam penetration and saturation, and allow proper drainage of condensate. Additionally, correct loading will prevent damage to packs and their contents and maximize efficient use of the sterilizer.

For detailed loading instructions, see para. 2.6 (Loading Capacities) and para. 7 (Preparation before sterilization)

### 8.4 Operations

- To seal the chamber, close the door then lift the handle of the tightening bolt in vertical position, and then rotate it clockwise until the bolt is hand tight. The operational message “Door is open”  disappears indicating the door is closed. Once the sterilization cycle is in progress, a safety device locks the door and makes it impossible to open it until completion of the cycle or a manual stop is executed.

**NOTE: Due to the inherent elasticity of the door gasket, the operational message “Door is open” may disappear before a complete seal is made between the door and the chamber. In order to ensure the chamber is fully sealed when the operational message and symbol “Door is open” disappears, continue to tighten the door bolt until it is hand tight. Do not over-tighten the bolt as this may result in damage to the gasket.**

**Should the autoclave fail to reach sterilizing temperature/pressure, always check first that the door is fully sealed. If not, tighten the door bolt further, as described above, until a complete seal is made.**

- Select the required program by means of the keys **UP▲**, **DOWN▼** and **START/STOP●**.
  - **UP** key: next program
  - **DOWN** key: previous program
  - **START/STOP** key: start the selected program

### 8.5 *End of the Cycle*

- At the end of the cycle the message “CYCLE END!” is displayed on the screen and the buzzer sounds one beep continuously during 3 seconds.
- In case the cycle has failed, the message “CYCLE FAIL!” is displayed on the screen, the buzzer sounds intermittently 3 beeps and an Error Message is displayed on the screen. (For corrective action see Displayed Error and Operational Messages sec 4.2) Pressing the **START/STOP** key will erase the fail message.

### 8.6 *Unloading*

- On completion of the cycle, open the door to remove the sterilized material from the autoclave. Rotate the handle of the tightening bolt counter-clockwise to the end then lower the bolt at a right angle, parallel to the front cover. Lift the door to a vertical position.

#### **Caution**



**Before opening the door, verify that there is no pressure in the chamber (a chamber pressure gauge is located on the autoclave's side cover).**

**Open the door slowly to allow steam to escape. DO NOT put your head or any other part of your body above the chamber. Doing so can cause injury from hot steam.**

- Take the load out of the sterilizer immediately upon completion of the cycle. Do not remove the load from the basket until its temperature has returned to room temperature. Let the load cool down in an area without air movement (air conditioning, etc.) and with minimum people passing by to avoid the possibility of touching the hot load. Do not touch the hot load since a hot load will absorb moisture and, therefore, may absorb bacteria from your hand. Perform a visual inspection to ascertain that sterilizing indicators have made the required color change, and that the load is dry.
- The load shall be rejected if:
  - a. The package has been compressed.
  - b. The package is torn.
  - c. The load is suspected to be wet.
  - d. The load fell on the floor.
  - e. Condensed drops can be detected on the load.



**To avoid injuries use heat resistant gloves while unloading the autoclave.**

**8.7 *Stopping the Process***

- It is possible to stop the program while the autoclave is in process. Pressing the START/STOP key at any stage of process, stops the operation.

**8.8 *Safety***

- Protective equipment and clothes and other safety instructions should be implemented in accordance with local and national regulations and/or rules!
- For proper sterilization - Do not overload the chamber. Only autoclavable products shall be used; please refer to the manufacturer instructions for sterilization of unknown materials or instruments.

## 9 **DOOR SAFETY SYSTEM**

The door opening is secured by two safety means:

1. A screw-type mechanical closing device that tightens the door and prevents an accidental door opening.
2. A pull-type locking solenoid that, in the inactivated position, locks the door and must be electrically powered to release the lock and enable opening of the door.

### 9.1 **Solenoid Locking Safety Device**

The solenoid locks the door in the following situations:

1. When the control unit is not powered.
2. If power failed or has been turned off while the autoclave is in operation, even if power has been restored.
3. If operation was stopped before completion of the cycle as a result of a failure or a manual stop.
4. The autoclave is equipped with two temperature sensors. If one of them senses that the temperature inside the autoclave chamber is higher than the “end of cycle” temperature, preset by the operator; the opening of the door is prevented. Opening the door is possible only when the temperature has dropped below preset "End-Temp" value.

For cases described at points 2 and 3, press START/STOP key to cancel the door locking at the end of the operation.

### 9.2 **Emergency Release**

An access hole is provided in the closing device to allow release of the locking pin when the power is off.

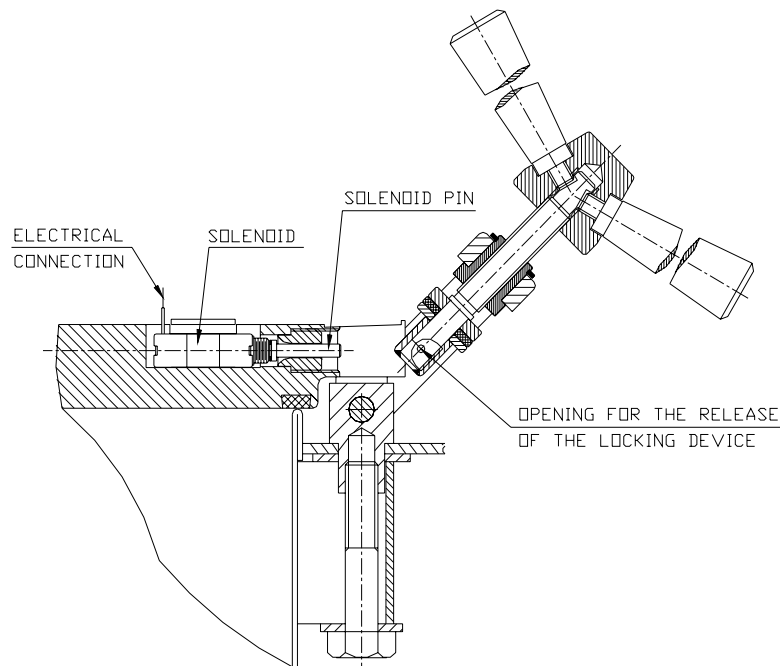

## 10 SERVICE AND MAINTENANCE

### 10.1 Preventive Maintenance

The maintenance operations described in this chapter must be fulfilled periodically in order to keep the autoclave in good working condition and to keep any breakdown time to a minimum.

The user's maintenance personnel can easily perform these operations.

The owner of the autoclave is responsible to have an authorized technician perform the periodical tests and preventive maintenance operations, as specified in the technician manual.

Use only mineral-free water as detailed in para. 2.9 (water quality).

#### Warning



**Before carrying out any preventive maintenance operation, ensure that the electrical cord is disconnected and there is no pressure in the autoclave.**

#### 10.1.1 Daily

Clean the door gasket with a soft cloth using water and a mild soapy solution. The gasket should be clean and smooth.

#### 10.1.2 Weekly

1. Remove the baskets (if applicable). Clean the chamber and baskets with a cleaning agent & water and with a cloth sponge. You may use diluted lemon acid (25-50 CC lemon acid in 1 liter of water) as cleaning agent. If detergent is used, rinse baskets immediately with water to avoid stains on the metal.



#### Caution

**Do not use steel wool or steel brush as this can damage the chamber!**

To remove the used water, open the water outlet strainer (see para. 10.5)



#### Caution

**Place a shallow pan under the strainer or water will spill on the floor!**

2. Put a few drops of oil on the two door pins and door tightening bolts.
3. Clean outer parts of the autoclave with a soft cloth.
4. Clean the electrode with a soft cloth.

#### 10.1.3 Periodically

1. Every 6 months replace the air filter, (if installed) according to para. 10.2.
2. Every 6 months clean the electronic box with compressed air, from inside outward.
3. Check the door gasket every 12 months and replace it if required (see para. 10.3).
4. Once a year check and tighten the piping joints to avoid leakage.
5. Once a year check and tighten all screw connections in the control box, heaters, valves and instrumentation.

6. Once a month clean the strainer as per para. 10.5. Cleaning frequency may be reduced according to experience.

**10.1.4 Periodical Tests**

1. Once every month activate the safety valve (see para. 10.4).

## 10.2 Replacing the Air Filter (ELVC only)

During the cooling phase, of the Liquid w/cooling cycle, compressed air is used to maintain pressure inside the chamber. The air filter ensures that the compressed air is pure and free from contaminants before entering the chamber. The air filtration is performed by a high quality bacteriological filter.

The filter is mounted at the right side of the autoclave. .

To replace the filter proceed as follows:

1. Open the right service door of the autoclave.
2. Unscrew the fittings (upper and lower fitting) connecting the filter to the piping.
3. Replace the filter with a new one and reconnect the fittings.
4. Close the service door.

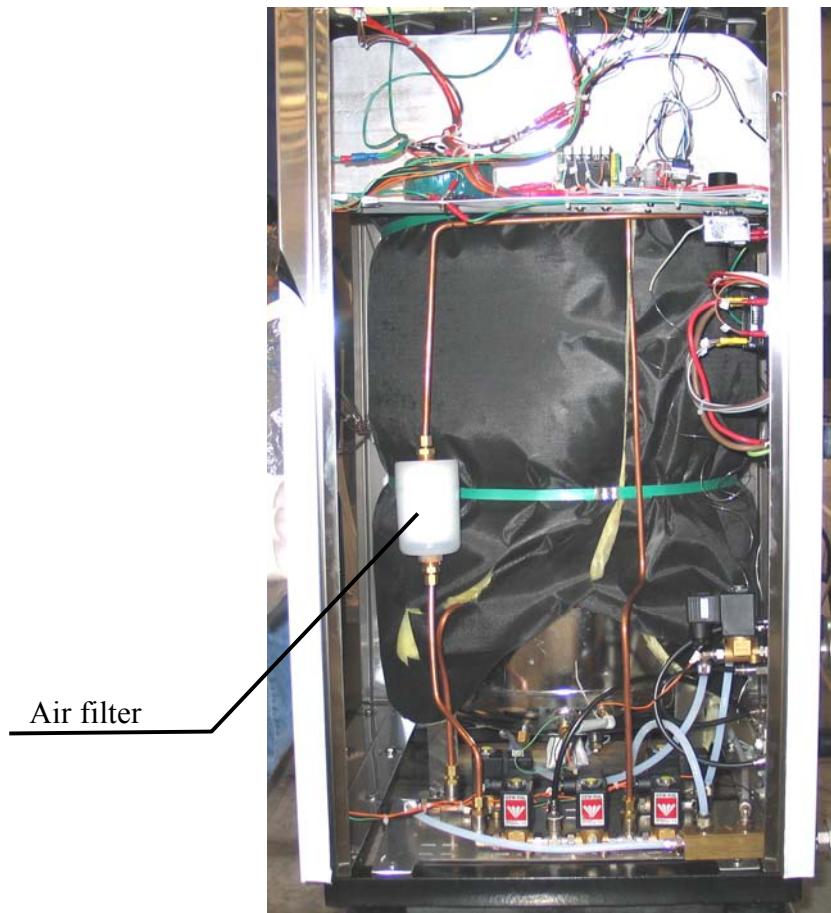

### 10.3 Replacing the Door Gasket

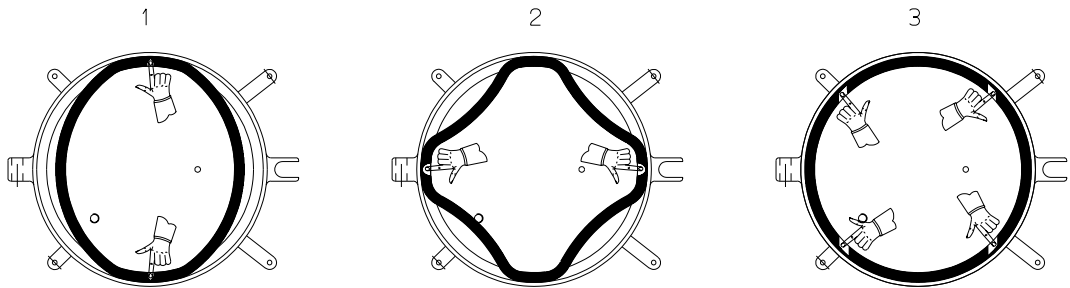

Pull off the gasket from the door groove and install the new gasket referring to the drawings as above points 1, 2 and 3.



**Caution!**

**This gasket is designed with a trapezoidal cross section. The gasket should be placed with the widest side towards the door.**



#### 10.4 *Checking the Safety Valve*

The safety valve is located on the rear side of the autoclave

In order to prevent the safety valve from becoming blocked, it is necessary to manually operate it once a month as follows:

1. Select the #1 Unwrapped Instrument sterilization cycle and run it according to the manual, making sure there are no instruments in the chamber.
2. Allow a pressure of approximately 29 psi (200 kPa) to build up in the chamber.
4. Operate the safety valve by pulling the ring of the safety valve using a tool, i.e. screwdriver, hook etc and lift the safety valve ring for 2 seconds. Be careful not to burn your hands.
5. Press the STOP key to abort the cycle and exhaust steam from chamber.
6. Wait until pressure goes down to zero, only then can the door be opened.



**CAUTION:** *To avoid being burned by the hot steam stand away from the Safety Valve.*



**ATTENTION:** *Use protective gloves in order not to burn your hands with the hot steam.*

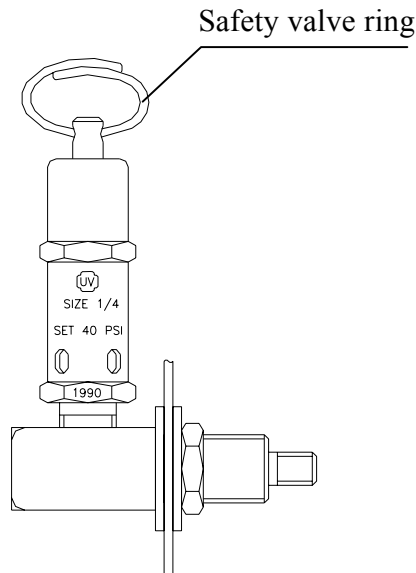

### 10.5 Cleaning Water Outlet Strainer



**Caution!**

Before proceeding, Make sure that the electric cord is disconnected and there is no pressure in the autoclave.



**Warning!**

The strainer cover may be HOT. Use heat resistant gloves to avoid being burned.



**Caution**

Place a shallow pan under the strainer or water will spill on the floor!

1. Open the left service door.
2. Open the strainer cap.
3. Remove the strainer element.
4. Rinse the strainer with water, using a brush if necessary.
5. Reinstall the strainer element.
6. Close the strainer cap.
7. Close the left service door.



**Attention:**

Ensure the silicon gasket is in place, A missing gasket will cause the strainer to leak.



Strainer

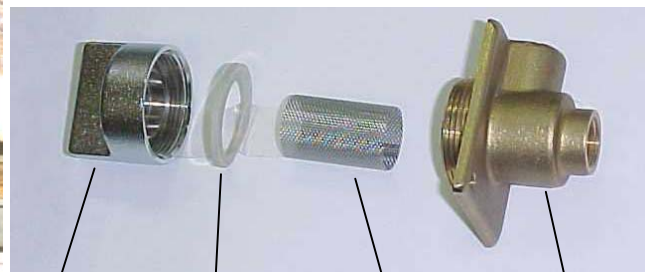

Cap

Silicon gasket

Strainer element

Strainer housing

## 11 TROUBLESHOOTING

*This troubleshooting chart enables the user to solve minor malfunctions prior to requesting service.*

*Only technical personnel having proper qualifications and holding technical documentation (including a technician manual) and adequate information are authorized to service the apparatus.*

<i>Problem</i>	<i>Solution</i>
1. Display is not activated	1.1. Check the power source and verify that it is according to specifications. 1.2. Verify that the ON/OFF switch is in the 'On' position. 1.3. Make sure the power cord is properly connected to the machine and the mains (see rear view drawing). 1.4. Check the reset button on the cut-out thermostat. Reset if necessary. 1.5. Make sure the circuit breaker has not tripped. Reset if necessary.
2. The printer prints, but nothing is printed on the paper	2.1. Verify that the printing paper is inserted correctly (see para. 6.3.1 Printing Paper)
3. The printer does not print	3.1. Make sure the paper is inserted in the printer (see para. 6.3.1 Printing Paper) 3.2. Contact your dealer to solve the problem.
4. When the machine is switched on, the printer feeds paper all the time	4.1. Contact your dealer to solve the problem.
5. The machine is leaking at the door	5.1. Make sure the door is tightened enough. 5.2. Replace the door gasket (see para. 10.3 Replacing the Door Gasket)
6. Water does not exit chamber due to clogged outlet strainer.	6.1. Clean strainer according to instructions (see sec 10.5).
<b>If the above recommendations did not correct the malfunction, or if any problems not discussed in this section were encountered, please contact your dealer for further assistance. You may also contact the distributor at the address on the front cover of this manual.</b>	

**BASKETS AND CONTAINERS**



**Container for waste products**

**Large Basket**

**Small Basket**

Type	Stainless steel wire baskets		Stainless steel container for waste products, with vent holes	
	Dia. x Height (mm)	Capacity	Dia. x Height (mm)	Capacity
2540	227 x 350	1	236 x 350	1
	227 x 178	2	236 x 190	2
3850	357 x 330	1	366 x 330	1
	357 x 220	2	366 x 220	2
3870	357 x 330	2	366 x 330	2
	357 x 220	3	366 x 220	3

**12 SPARE PARTS LIST**

Description	Cat. No.	
	2540	3850, 3870
Cable, Electric, Plug	02819996	—
Cap for ¼” strainer	FIL175-0027	FIL175-0027
Strainer element	FIL175-0006	FIL175-0006
Teflon gasket 4 mm	GAS082-0008	GAS082-0008
Door gasket	02610023	02610019

**13 ACCESSORIES**

Description		Cat. No.	
		2540	3850, 3870
Paper, Roll, Printer, DPU-30 (pack of 5)		01610406	01610406
Stainless steel wire basket	Large	BSK254-0001	BSK387-0001
	Small	BSK254-0004	BSK387-0002
Stainless steel container for waste products, with vents holes	Large	BSK254-0005	BSK387-0005
	Small	BSK254-0003	BSK387-0003